

OWNER'S MANUAL

CRAFTSMAN®

9.0 Horsepower 3000 PSI 3 GPM High Pressure Washer

Model No:
919.763010

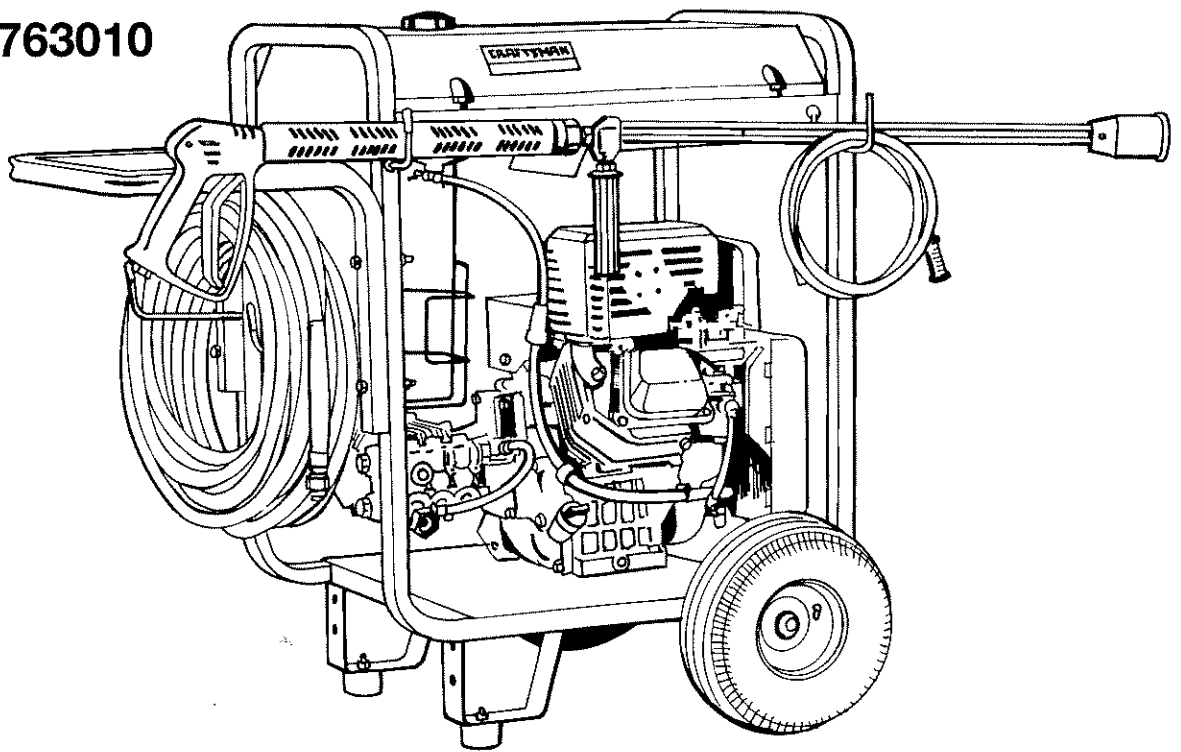

WARNING: Before using this product, read this manual and follow all Safety Rules and Operating Instructions.

**PRESSURE WASHER
CUSTOMER
HELPLINE
1-800-245-5873**

- Safety
- Assembly
- Operation
- Maintenance
- Parts List
- Español

Sears, Roebuck and Co., Hoffman Estates, IL 60179 U.S.A.

TABLE OF CONTENTS

Warranty	2	Storage	14
Safety Guidelines	3-5	Troubleshooting	15
Assembly	5-7	Parts.....	16-33
Operation	7-10	EPA Codes.....	34-35
Maintenance.....	11-13	How to Order Parts	Back Cover
		Español	35-55

LIMITED ONE YEAR WARRANTY ON CRAFTSMAN HIGH PRESSURE WASHER

For one year from the date of purchase, when this Craftsman High Pressure Washer is maintained and operated according to the instructions in the owner's manual, Sears will repair, free of charge, any defect in material and workmanship.

If your Craftsman Pressure Washer is used for commercial or rental purposes, this warranty applies only for 90 days from the date of purchase.

LIMITED ONE YEAR WARRANTY ON CRAFTSMAN ENGINE

For one year from the date of purchase, when this Craftsman engine is maintained and operated according to the instructions in the owner's manual, Sears will repair, free of charge, any defect in material and workmanship.

If your Craftsman engine is used for commercial or rental purposes, this warranty applies only for 90 days from the date of purchase. This warranty does not cover: Expendable items such as spark plugs and air filters, which become worn during normal use.

Repairs necessary because of operator abuse or negligence, including damage resulting from no water being supplied to pump or failure to maintain the equipment according to the instructions contained in the owner's manual, are not covered under warranty.

WARRANTY SERVICE IS AVAILABLE BY RETURNING THE HIGH PRESSURE WASHER TO THE NEAREST SEARS SERVICE CENTER/DEPARTMENT THROUGHOUT THE UNITED STATES.

This, warranty gives you specific legal rights and you may also have other rights, which vary from state to state.

Sears, Roebuck and Co., D/817 WA, Hoffman Estates, IL 60179

SAFETY GUIDELINES - DEFINITIONS

This manual contains information that is important for you to know and understand. This information relates to protecting **YOUR SAFETY** and **PREVENTING EQUIPMENT PROBLEMS**. To help you recognize this information, we use the symbols below. Please read the manual and pay attention to these sections. **SAVE THESE DEFINITIONS/INSTRUCTIONS.**

▲ **WARNING** indicates a potentially hazardous situation which, if not avoided, **could** result in **death or serious injury**.

▲ **DANGER** indicates an imminently hazardous situation which, if not avoided, **will** result in **death or serious injury**.



▲ **CAUTION** indicates a potentially hazardous situation which, if not avoided, **may** result in **minor or moderate injury**.

10/2/97





IMPORTANT SAFETY INSTRUCTIONS

▲ WARNING



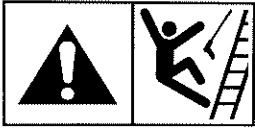



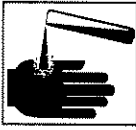

Improper operation or maintenance of this product could result in serious injury and property damage. Read and understand all warnings and operating instructions before using.

HAZARD	WHAT CAN HAPPEN	HOW TO PREVENT IT
<p>▲ DANGER</p> <p>RISK OF EXPLOSION OR FIRE</p> 	<ul style="list-style-type: none"> • Spilled gasoline and its vapors can become ignited from cigarette sparks, electrical arcing, exhaust gases, and hot engine components such as the muffler. • Heat will expand fuel in the tank which could result in spillage and possible fire explosion. • Operating the pressure washer in an explosive environment could result in a fire. • Materials placed against or near the pressure washer can interfere with its proper ventilation features causing overheating and possible ignition of the materials. • Improperly stored fuel could lead to accidental ignition. Fuel improperly secured could get into the hands of children or other unqualified persons. 	<ul style="list-style-type: none"> • Shut off engine and allow it to cool before adding fuel to the tank. • Use care in filling tank to avoid spilling fuel. Move pressure washer away from fueling area before starting engine. • Keep maximum fuel level ½" below top of tank to allow for expansion. • Operate and fuel equipment in well ventilated areas free from obstructions. Equip areas with fire extinguishers suitable for gasoline fires. • Never operate pressure washer in an area containing dry brush or weeds. • Store fuel in container approved for gasoline, in a secure location away from work area.
<p>▲ DANGER</p> <p>RISK TO BREATHING</p> 	<ul style="list-style-type: none"> • Breathing exhaust fumes will cause serious injury or death. • Some cleaning fluids contain substances which could cause injury to skin, eyes, or lungs. 	<ul style="list-style-type: none"> • Operate pressure washer in a well ventilated area. Avoid enclosed areas such as garages, basements, etc. • Never operate unit in a location occupied by humans or animals. • Use only cleaning fluids specifically recommended for high pressure washers. Follow manufacturers recommendations.

IMPORTANT SAFETY INSTRUCTIONS (cont'd)

HAZARD	WHAT CAN HAPPEN	HOW TO PREVENT IT
<p style="text-align: center;">⚠ WARNING RISK OF UNSAFE OPERATION</p> 	<ul style="list-style-type: none"> • Unsafe operation of your pressure washer could lead to serious injury or death to you or others. • The spray gun/wand is a powerful cleaning tool that could look like a toy to a child. • Reactive force of spray will cause gun/wand to move, and could cause the operator to slip or fall, or misdirect the spray. Improper control of gun/wand can result in injuries to self and others. 	<ul style="list-style-type: none"> • Become familiar with the operation and controls of the pressure washer. • Keep children away from the pressure washer at all times. • Never defeat the safety features of this product. • Do not operate machine with missing, broken, or unauthorized parts. • Never leave wand unattended while unit is running. • Keep work area free of obstacles. • Stand on a stable surface and grip gun/wand firmly. Expect the gun to kick when triggered.
<p style="text-align: center;">⚠ WARNING RISK OF INJURY FROM SPRAY</p> 	<ul style="list-style-type: none"> • High velocity fluid spray can cause objects to break, propelling particles at high speed. • Light or unsecured objects can become hazardous projectiles. 	<ul style="list-style-type: none"> • Always wear ANSI approved Z87 safety glasses. Wear protective clothing to protect against accidental spraying. • Never point wand at, or spray people or animals. • Always secure trigger lock when wand is not in service to prevent accidental operation. • Never permanently secure trigger in pull back (open) position.
<p style="text-align: center;">⚠ WARNING RISK OF ELECTRICAL SHOCK</p> 	<ul style="list-style-type: none"> • Spray directed at electrical outlets or switches, or objects connected to an electrical circuit, could result in a fatal electrical shock. 	<ul style="list-style-type: none"> • Unplug any electrically operated product before attempting to clean it. Direct spray away from electric outlets and switches.
<p style="text-align: center;">⚠ WARNING RISK OF FLUID INJECTION</p> 	<ul style="list-style-type: none"> • Your washer operates at fluid pressures and velocities high enough to penetrate human and animal flesh, which could result in amputation or other serious injury. Leaks caused by loose fittings or worn or damaged hoses can result in injection injuries. DO NOT TREAT FLUID INJECTION AS A SIMPLE CUT! See a physician immediately! • Relieve system pressure before attempting maintenance or disassembly of equipment. 	<ul style="list-style-type: none"> • Never place hands in front of nozzle. • Direct spray away from self and others. • Make sure hose and fittings are tightened and in good condition. Never hold onto the hose or fittings during operation. • Do not allow hose to contact muffler. • Never attach or remove wand or hose fittings while system is pressurized. • Use only hose and high pressure accessories rated for 2000 PSI service. • To relieve system pressure, shut off engine, turn off water supply, and pull gun trigger until water stops flowing.
<p style="text-align: center;">⚠ WARNING RISK OF CHEMICAL BURN</p> 	<ul style="list-style-type: none"> • Use of acids, toxic or corrosive chemicals, poisons, insecticides, or any kind of flammable solvent with this product could result in serious injury or death. 	<ul style="list-style-type: none"> • Do not use acids, gasoline, kerosene, or any other flammable materials in this product. Use only household detergents, cleaners and degreasers recommended for use in pressure washers. • Wear protective clothing to protect eyes and skin from contact with sprayed materials.

IMPORTANT SAFETY INSTRUCTIONS (cont'd)

HAZARD	WHAT CAN HAPPEN	HOW TO PREVENT IT
<p>⚠ WARNING RISK OF HOT SURFACES</p> 	<ul style="list-style-type: none"> Contact with hot surfaces, such as engines exhaust components, could result in serious burn. 	<ul style="list-style-type: none"> During operation, touch only the control surfaces of the pressure washer. Keep children away from the pressure washer at all times. They may not be able to recognize the hazards of this product.
<p>International Symbols</p>	  <p>Safety Alert - Read Owner's Manual</p>	 On Off  Stop  Fuel Shutoff  Fuel  Choke

IMPORTANT:

The powerful spray from your pressure washer is capable of causing damage to fragile surfaces such as: wood, glass, automobile paint, auto stripping and trim, and delicate objects such as flowers and shrubs. Before spraying, check the item to be cleaned to assure yourself that it is robust enough to resist damage from the force of the spray. Avoid the use of the concentrated spray stream except for very strong surfaces like concrete and steel.

Operating unit with water supply shut off without flow of water will result in equipment damage. You should never run this pressure washer for more than 2 minutes without pulling the trigger to allow cool water to enter the pump and the heated (recirculated) water to exit. Running the pressure washer with water supply shut off will void your warranty.

ASSEMBLY

Carton Contents

- Main Unit pressure washer with wheels
- Handle
- High Pressure Hose
- Chemical Pickup Hose and Filter
- Bag Containing
 - Video Cassette
 - Owners' Manual
 - Nozzle Cleaning Kit and Replacement O-Rings
 - Rubber Isolator and Mounting Hardware
- Box Containing
 - Gun
 - Wand
 - Engine Oil
 - Handle Mounting Hardware

Tools Required for Assembly

- Adjustable wrench
- 1/2" Socket wrench

Remove Pressure Washer from Carton

- Open box from the top. Locate and remove from box, the parts box, which includes gun, handle, wand, oil, nuts bolts and washers for handle installation.
- Cut carton along dotted lines.
- Remove all carton inserts.
- Roll unit through opening in carton.

NOTE: The hose is located at the bottom of the box.

Preparing the Pressure Washer for First Use

- Note:** Included with your pressure washer is a video tape on how to prepare your unit for operation. It is recommended you view this tape before performing the next steps.
- Place handle on frame.
 - Insert bolts into holes provided in handle.
 - Line up handle and bolts with the holes provided on frame.
 - Insert bolts through holes in frame.
 - Place washers and over inserted bolts. Next place nuts over bolts and tighten with adjustable wrench turning in clockwise direction.

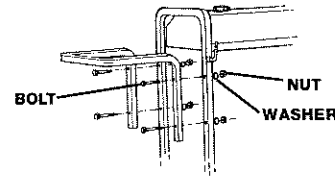

- Attach chemical basket to the pressure washer frame opposite side of muffler. Holes are provided on frame.

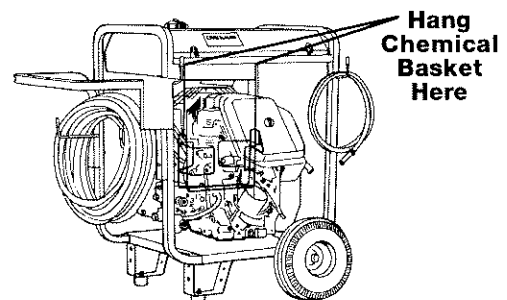

- Remove wood plank from the frame of the unit. An adjustable wrench is required. Discard bolt and board.

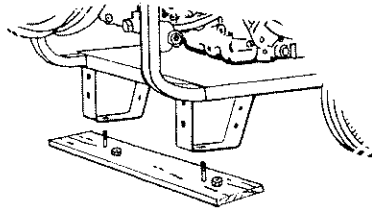

- Mount the rubber isolator to the frame. To mount isolator place threaded end of bolt through the washer. Next with washer on bolt place threaded end of bolt through the rubber isolator. Place threaded portion of isolator through the same hole location the wood plank was mounted to on the pressure washer. Next place lockwasher over threaded portion of nut that has been placed through the mounting hole in the pressure washer and use nut to tighten isolator to the frame. Tighten nut with an adjustable wrench. All isolator parts are supplied in parts bag.

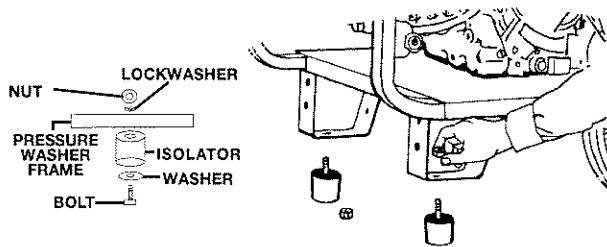

- Connect wand with nozzle extension to gun. To tighten, turn knob in clockwise direction. Hand tighten.

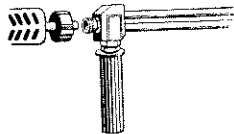

- Cut tie wrap off of high pressure hose. Unwind high pressure hose to attach the threaded end to the gun.

NOTE: Do not remove Teflon tape on threads.

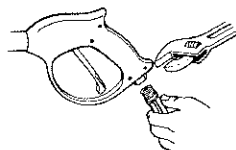

- Connect chemical hose to the chemical injector nipple on the pump.

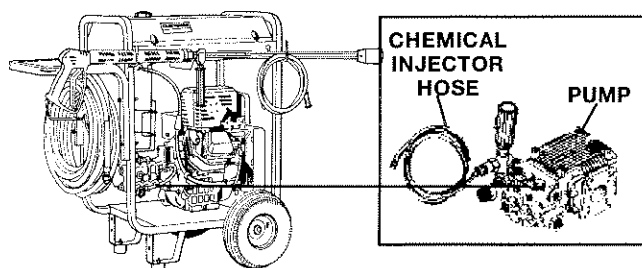

- Connect high pressure hose to the quick connect outlet on pressure washer.

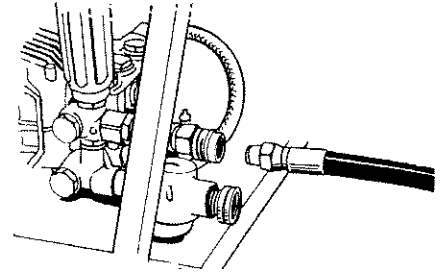

NOTE: Keep hose away from engine muffler.

- Place assembled gun and wand on pressure washer holder.

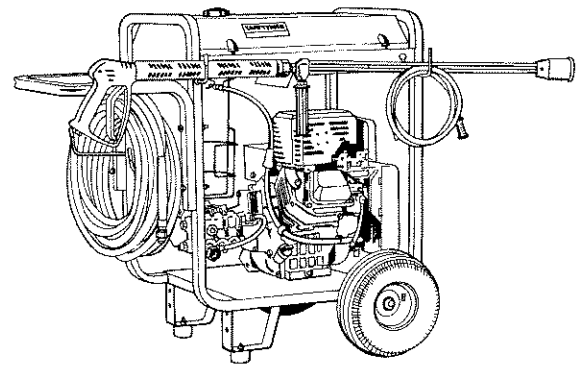

NOTE: Your unit's pump is shipped with a temporary plug that must be replaced with a breather cap. This plug is located over the pump's oil port. Unscrew and remove this plug. Remove the breather cap from the bag attached to the plug and install it in the pump's oil port.

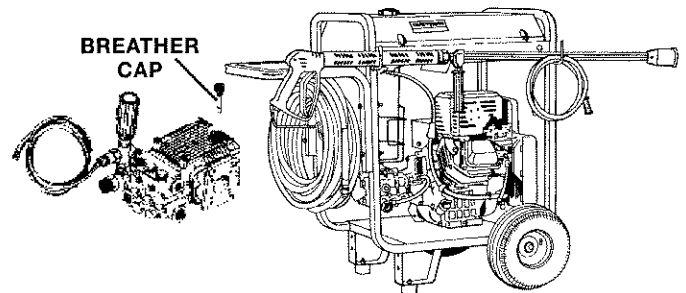

▲ CAUTION: Failure to replace the plug will result in serious pump damage.

Checklist

Before going any further please review the following:

- Be sure you have completed assembly instruction.
- Double check all fittings to be sure they are tight.

IMPORTANT: Before any attempt to start your pressure washer be sure to check engine oil (See Operation under Adding Engine Oil.)

OPERATION

Know Your High Pressure Washer

Read this Owner's Manual and Safety Rules before operation of your High Pressure Washer Compare this illustration with our pressure washer to familiarize yourself with the location of various controls and adjustments. Save this manual for future reference.

PUMP- Develops high pressure.

ENGINE OIL FILL- Place where engine oil is poured.

PRESSURE REGULATOR- Allows you to adjust the pressure of the outlet stream.

ENGINE RUN/STOP SWITCH- Sets engine in starting mode for recoil starter — **Stops** running engine.

RECOIL STARTER- Used for starting the engine manually.

SPRAY GUN ASSEMBLY- Controls the application of water onto cleaning surface with trigger device.

PUMP OIL FILL- Port where pump oil is poured and breather cap is located.

GAS TANK/CAP- Cap is removed and unleaded gasoline is poured.

CHEMICAL INJECTION TUBE AND FILTER- Mixes water and detergent in outlet water flow.

HIGH PRESSURE OUTLET- Connection for high pressure hose.

CHOKE- Lever used for starting unit.

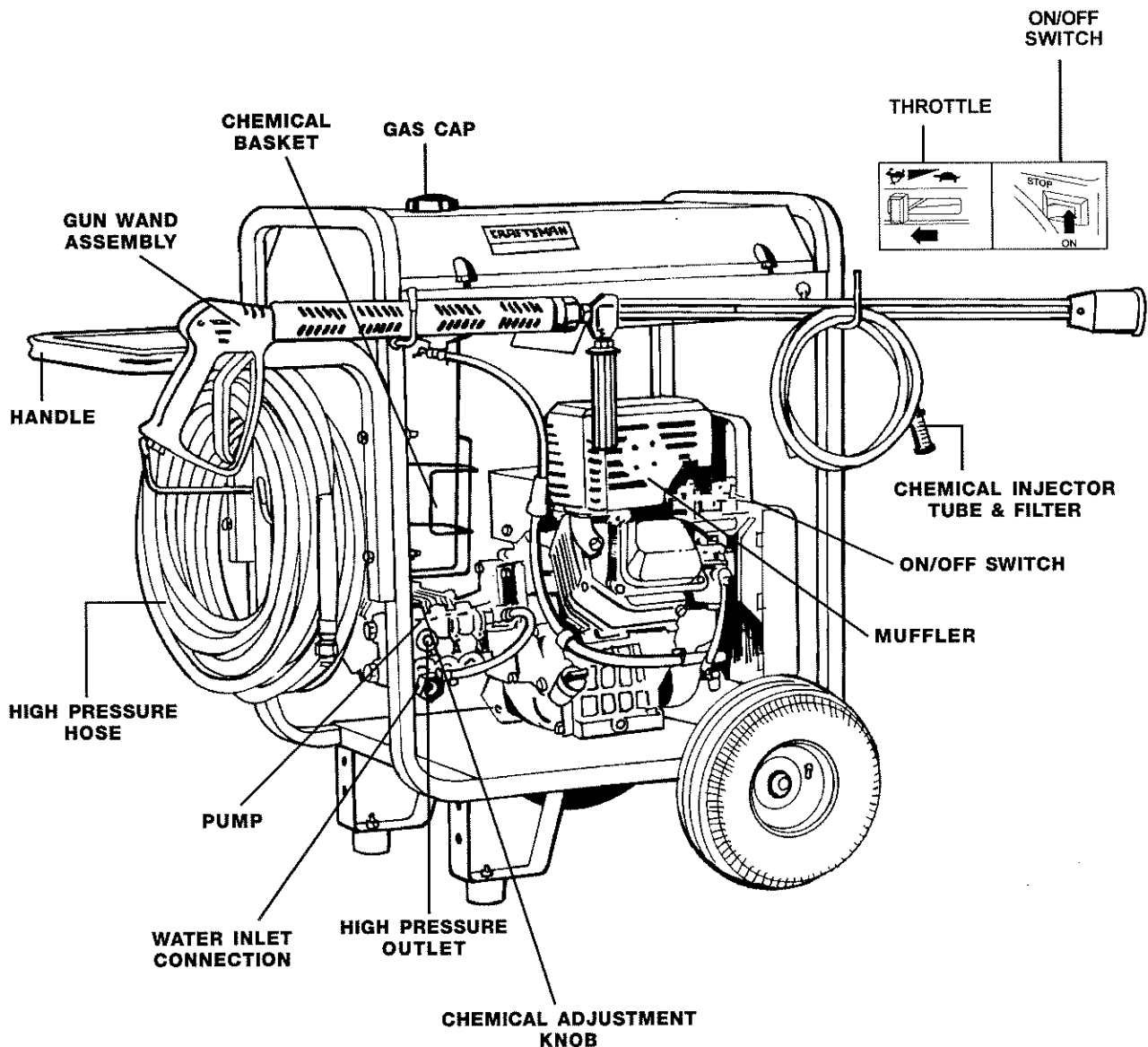

▲ Warning: Read Owner's Manual. Do not attempt to operate equipment until you have read Owners Manual for Safety, Operation, and Maintenance Instructions.

Note: Included with your unit is a video cassette that demonstrates how to operate your pressure washer. If you have a video cassette recorder you should view the video before operation.

▲ Warning: Never adjust spray pattern when spraying. Never put hands in front of spray nozzle to adjust spray pattern because you could be injured.

How To Use Your Pressure Washer

On the end of your spray gun is a handle that you can twist from side to side. With this handle you can adjust the spray pattern to either high pressure or low pressure.

- Twist the handle in a clockwise direction to achieve low pressure. Twist handle counterclockwise for high pressure.

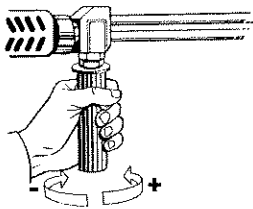

- For most effective cleaning, keep spray nozzle between 8 and 24 inches of cleaning surface.

IMPORTANT: If you get spray nozzle too close, especially on high pressure, you may damage the cleaning surface.

- The pressure control knob is located on the pump. You can increase the pressure by turning the knob clockwise or decrease the pressure by turning the knob counterclockwise.

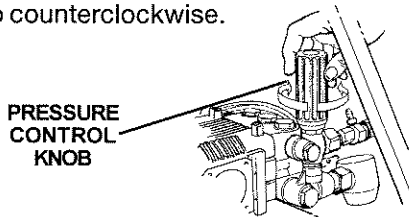

NOTE: The maximum pressure for the unit is factory adjusted. Do not attempt to adjust beyond this factory setting.

Using Soaps/Chemicals

IMPORTANT: Use soaps and chemicals that are designed specifically for use with pressure washers. To apply soap/chemicals follow these steps:

- Prepare the soap/chemical as required by your job.
- Insert soap/chemical line into your container (soap/chemicals not included).

- Prepare the soap/chemical as required by your job.
- Insert soap/chemical line into your container (soap/chemicals not included).



NOTE: The first step involves applying an appropriate soap/chemical solution to penetrate and loosen grime. The soap/chemical applied at low pressure to avoid splashing, over spray and waste. Leave the solution on surface for 3 to 5 minutes to allow solution to work.

NOTE: The second step involves cleaning the surface you have prepared with the pressure washer and then rinsing it clean.

- Turn the adjustable nozzle counter clockwise to low pressure mode. Soap/chemicals cannot be applied with nozzle in high pressure position.
- Review the use of the adjustable nozzle.
- Connect garden hose to water inlet (see "To Start Your Pressure Washer"), check that high pressure hose is connected to spray gun and pump (see *Assembly*), and start engine.
- Apply soap/chemicals to dry surface, starting from the bottom and working up.
- Allow the soap/chemicals to soak in between 3-5 minutes before washing and rinsing.
- For cleaning, start at lower portion of area to be washed and work upward, using long, even overlapping strokes.

Your pressure washer is equipped with a chemical injector adjustment knob. With the knob fully opened you will get a 7 to 1 water to chemical ratio. With knob fully closed you will get **no** chemical draw. Turn knob in clockwise direction to achieve more chemical draw and counterclockwise for less chemical draw.

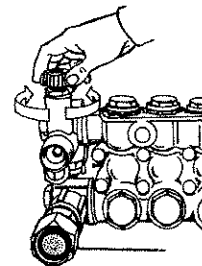

- After using the pressure washer, it is recommended the pump, chemical injector and chemical line be flushed with clear water. To do so, simply place chemical injector hose in water and siphon for 1 to 2 minutes.

Stopping Your Pressure Washer

▲ CAUTION: Do not run pump without the water supply connected and turned on. Failure to do so will result in pump damage.

- To turn pressure washer off place the on/off switch to the off position.

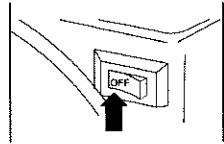

- Simply shutting OFF engine will not release pressure in the system. Squeeze the trigger on the spray gun for about 3 seconds to relieve pressure. Spray stream will decrease in length.

IMPORTANT: This unit is equipped with a thermal relief valve. If unit is allowed to run for several minutes without pressing the trigger on the spray gun, several drops of water may be released through this valve to cool the unit. This small amount of water will drip from the bottom of the pump.

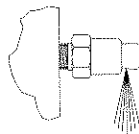

BEFORE STARTING THE ENGINE

To operate the engine you will need to do the following.

▲ CAUTION: Always check engine oil level before every start. Running engine low of oil or out of oil could result in serious damage.

▲ CAUTION: Always check pump oil level before every start. Running pump low on oil could result in pump damage.

Adding Pump Oil

Before running the high pressure washer, check the pump oil level by viewing the sight glass on the side of the pump. When properly filled, the oil will be at the half way point marked by the two triangles. Your pressure washer pump is shipped with oil. Add only if oil level is lower than the half way point on the sight glass. **Do not overfill.** Use 30 weight non-detergent oil if necessary.

▲ CAUTION: Do Not use engine oil that has been shipped with your unit in your pump. Engine oil is detergent and your pump uses a non-detergent oil. Detergent oil can cause damage to your pump.

Engine Oil

Your unit has been shipped without oil in the engine. A bottle of SAE 30 weight oil is included in the carton. Remove oil dip stick located on the side of engine. The oil dip stick is clearly marked with a lines that tells you when unit has enough oil. Do not fill above this point. Pour slowly.

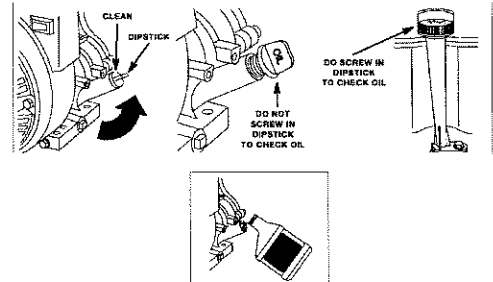

NOTE: When adding oil to the engine crankcase, use a high quality detergent oil classified "For Service SF, SG, SH rated SAE 30 weight. Use no special additives. Select the oil's viscosity grade according to your expected operating temperatures.

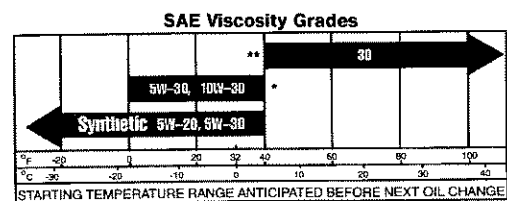

Air cooled engines run hotter than automotive engines. The use of multi-viscosity oil such as (10W-30, etc.) in ambient temperatures above 40°F (4°C) will result in higher than normal oil consumption. If multi-viscosity oil is used, check the oil level more frequently to prevent any possible engine damage due to lack of lubrication.

Use of SAE30 oil below 40°F (4°C) will result in hard starting and possible engine damage due to inadequate lubrication.

Gasoline

Your pressure washer engine is 4 cycle. Use unleaded fuel only.

▲ CAUTION: Do not overfill the fuel tank. Always allow room for fuel expansion.

▲ WARNING: Never fill fuel tank indoors. Never fill fuel tank when engine is running or hot. Do not smoke or have open flame when filling fuel tank.

Use clean, fresh, regular unleaded gasoline with a minimum of 85 octane. Do not mix oil with gasoline. If unleaded fuel is not available, leaded fuel may be used.

IMPORTANT: It is important to prevent gum deposits from forming in essential fuel system parts such as the carburetor, fuel filter hose or tank during storage. Also, experience indicates that alcohol-blended fuels (called gasohol or using ethanol or methanol) can attract moisture which leads to separation and formation of acids during storage. Acidic gas can damage the fuel system of an engine while in storage. To avoid engine problems, the fuel system should be emptied before storage of 30 days or longer. Never use engine or carburetor cleaner products in the fuel tank or permanent damage may occur.

NOTE: Never start pressure washer without water source turned on and connected to pressure washer.

To Start Your Pressure Washer

Make sure fuel shutoff valve is turned to the open position. Turn counter-clockwise to open.

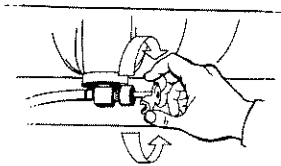

- Remove gas cap.
- Add unleaded gasoline, slowly, to fuel tank.
- Do not overfill.

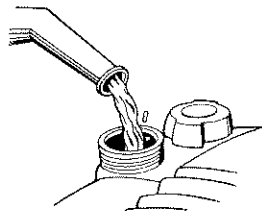

- Connect garden hose to the water inlet on the pressure washer. Tighten by turning water inlet counterclockwise.

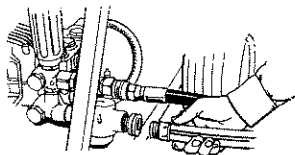

- Connect high pressure hose to discharge on pump.
- Connect the garden hose to the water spout and turn water supply on.

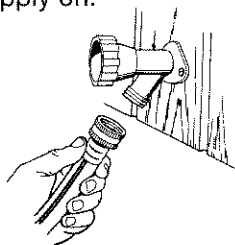

- Squeeze trigger on pressure washer wand to relieve air pressure caused by turning on the water. Water will spew out of the gun in a thin stream. This will make it easier to start the engine.
- Engage the safety latch on the spray gun. This locks the trigger in place and keeps you from accidentally spraying a high pressure stream.

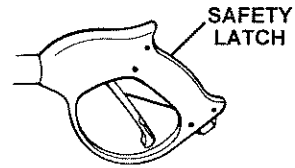

- On the engine there is a choke/run lever. Place lever to the choke position.

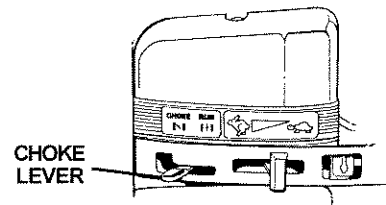

- On the engine there is a throttle control lever. Place throttle to the rabbit position. Always start engine with throttle in the rabbit position.

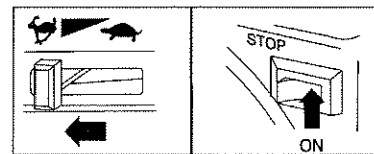

- Grasp the starter grip and pull slowly until resistance is felt, then pull firmly to start engine.
- Grasp the starter grip and pull slowly until resistance is felt, then pull firmly to start engine.
- When engine starts, gradually move choke lever to RUN position.
- If engine does not start after 5 pulls, place choke back to run position.
- For hot engine starts make sure choke lever is in the run position. Make sure fuel shut off valve is open and throttle is in the rabbit position.

NOTE: If any leaks are present shut unit down and tighten fittings.

MAINTENANCE

CUSTOMER RESPONSIBILITIES TABLE				
MAINTENANCE TASK	Before each use	Every 25 hours or yearly	Every 50 hours or yearly	Every 100 hours or yearly
PRESSURE WASHER				
Check/clean inlet screen.	x			
Check high pressure hose.	x			
Check soap and chemical hose and filter	x			
Check gun and wand for leaks.	x			
Purge pump of air and contaminants	x			
Check pump oil	x			
Change pump oil			x	
ENGINE				
Check oil level	x			
Change engine oil			x	

Product Specifications

Pressure Washer Specifications

Pressure	3000
Flow Rate	3.0 GPM
Cleaning Units (psi x GPM)	9000

Engine Specifications

RPM	3600
Rated Horsepower	9.0
Spark Plug	0.030" (0.76mm)
Gasoline Capacity	7 Gallon
Oil	SAE 30 weight

General Recommendations

The warranty of the high pressure washer does not cover items that have been subjected to operator abuse or negligence. To receive full value from the warranty, operator must maintain high pressure washer as instructed in this manual.

Some adjustments will need to be made periodically to maintain your high pressure washer.

All adjustments in the Maintenance section of this manual should be made at least once each season.

Once a year you should clean or replace the spark plug and clean or replace the air filter and check the gun and wand assembly for wear. A clean spark plug and clean air filter assure proper fuel-air mixture and help your engine run better and last longer.

NOTE: Over time the o-rings in the gun assembly become worn. Attach to your owners manual is a set of replacement o-ring and split backup ring.

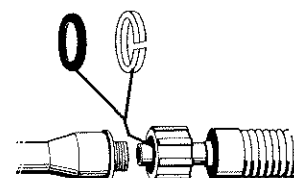

Pressure Washer Maintenance

Check and Clean Inlet Screen: Examine inlet screen on pump inlet fitting. Clean if clogged replace if torn.

Check High Pressure Hose: High pressure hose can develop leaks from wear, kinking, abuse. Inspect hose each time before use. Check for cuts, leaks, abrasions or bulging of cover, damage or movement of couplings. If any of these conditions exist, replace hose immediately.

Check Chemical/Soap Hose: Examine the chemical/soap hose and clean if clogged. Hose should fit tightly on pump fitting. Check for leaks and tears. Replace filter or hose if either is damaged.

Check Gun and Wand: Examine hose connection to gun making sure it is secure. Test trigger by pressing it and making sure it springs back into place when you release it.

Pump Oil

Pump oil level should be checked before each use.

Changing Pump Oil

Oil should be changed after the first 10 hours of operation. Subsequent changes after each 50 hours of operation. To drain oil, simply remove oil plug with an adjustable wrench. The oil plug is located at the bottom of the pump. Dispose of used oil. Properly remove pump oil fill plug. Add 30 weight non-detergent oil. Fill until oil level is at the mid point on the sight glass.

Purge Pump of Air and Contaminants

To remove the air from the pump, follow these steps:

- Set up the pressure washer as described in *Assembly* section and connect the water supply.
- Remove the wand extension from the spray gun.
- Pull the trigger on the gun and hold.

To remove the contaminants from the pump, follow these steps:

- Set up the pressure washer as described in *ASSEMBLY* section, connect the water supply.
- Remove the wand extension from the spray gun.
- Start the engine according to instructions in the *OPERATION* section.

- Pull the trigger on the gun and hold.
- When the water supply is steady and constant, disengage trigger and refasten the wand extension.

Engine Maintenance

Oil

- Oil level should be checked prior to each use or at least every 5 hours of operation. To check oil see *Adding Engine Oil* on page 9.

Changing Engine Oil

For a new engine, change oil after the first **5 hours** of operation. Thereafter, change oil after every **50 hours** of operation.

Change the oil while the engine is still warm. The oil will flow freely and carry away more impurities. Make sure the engine is level when filling, checking, or changing oil.

Change the oil as follows:

- To keep dirt, grass clippings, etc., out of the engine, clean the area around the drain plug and dipstick before removing it.
- Remove the oil drain plug and dipstick. Tilt the engine slightly towards the oil drain to obtain better drainage. Be sure to allow ample time for complete drainage.

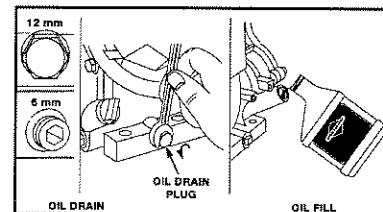

- Reinstall the drain plug. Make sure it is tightened securely.
- Fill the crankcase with new oil of the proper type, to the Full mark on the dipstick. Always check the level with the dipstick before adding more oil.

- Reinstall the oil fill cap or plug and tighten securely.

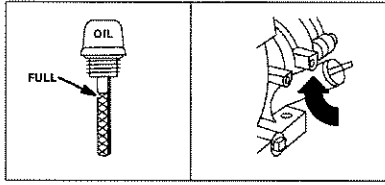

Do not clean engine with a forceful spray of water because water could contaminate fuel system. With a brush or cloth clean finger guard after every use to prevent engine damage caused by overheating.

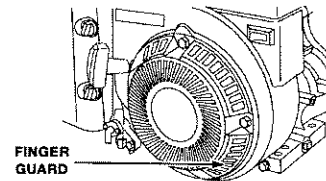

Service Air Cleaner

NOTE: Do not use petroleum solvents, e.g., kerosene, which will cause the cartridge to deteriorate. Do not use pressurized air to clean cartridge. Pressurized air can damage the cartridge.

To service air cleaner follow these steps:

1. Unscrew cover screws. Remove cover and air cleaner assembly.
2. Remove cartridge from cover, then retainer (if equipped) and pre-cleaner.

To service pre-cleaner, wash in liquid detergent and water. Squeeze dry in a clean cloth. Saturate in engine oil. Squeeze in clean, absorbent cloth to remove all **excess** oil. Replace if very dirty or damaged.

To service cartridge, clean by tapping gently on a flat surface. Do not oil cartridge. Replace if dirty or damaged.

NOTE: Do not use petroleum solvents, e.g., kerosene, which will cause the cartridge to deteriorate. Do not use **pressurized air** to clean cartridge. Pressurized air can damage the cartridge.

3. Reassemble pre-cleaner or retainer (if equipped.) Place in cover with pre-cleaner mesh side toward cartridge. Place cartridge in retainer in cover.
4. Push cover and air cleaner assembly squarely onto base (tabs must be in slots, if equipped) and hold firmly. Tighten cover screws securely.

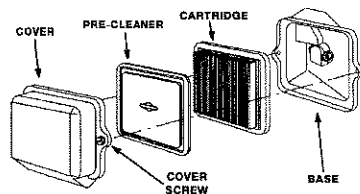

Keep engine and parts clean!

Before running engine, clean muffler area to remove all combustible debris.

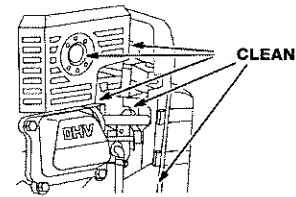

Clean and Replace Spark Plug

Change the spark plug every 100 hours of operation or once each year, whichever comes first. This will help your engine to start easier and run better.

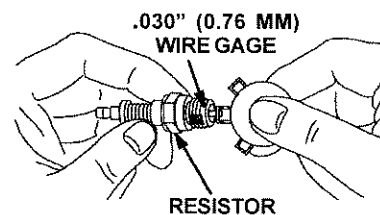

SERVICE AND ADJUSTMENTS

Carburetor

The carburetor of your high pressure washer is pre-set at the factory. The carburetor should not be tampered with. If your pressure washer is used at an altitude in excess of 5000 feet consult with your nearest Sears Service Center regarding high altitude set changes.

▲ CAUTION: Engine speed was properly adjusted at the factory and should require no additional adjustment. Do not attempt to change engine speed. If you believe the engine is running too fast or too slow, take your pressure washer to a Sears Authorized Service Center for repair and adjustment.

▲ High engine speeds are dangerous and increase the risk of personal injury or damage to equipment.

▲ Low engine speeds impose a heavy load on the engine and when sufficient engine power is not available could shorten engine life.

Nozzle Maintenance

Dual Lance:

1. Shut off the pressure washer and turn off the water supply.
2. Disconnect spark plug wire.
3. Pull trigger on gun handle to relieve any water pressure.
4. Disconnect the wand/lance from the gun.
5. Remove the high-pressure nozzle from the lance. Remove any obstructions with the nozzle cleaning tool provided and backflush with clean water.
6. Direct water supply into nozzle end to backflush loosened particles for 30 seconds.
7. Reassemble the nozzle to the lance using teflon tape to prevent leaks. Tighten securely.
8. Reconnect wand/lance to gun and turn on water supply.
9. Start pressure washer and place wand/lance into high pressure setting to test.

STORAGE

This pressure washer should be stored in such a way to protect it from freezing. Do not store this unit outdoors or in an area where temperatures will fall below 32° F. This can cause extensive damage to this unit.

If unit has to be stored under freezing conditions a non-toxic R.V. anti-freeze can be used to protect from freezing.

Preparing Pressure Washer for Storage

NOTE: If you do not plan to use your unit for 30 days or more, unit should be prepared for storage.

Engine Preparation

- First add a fuel stabilizer to the fuel tank.
- Run pressure washer for full 5 minutes to allow fuel stabilizer to enter the fuel system.

NOTE: While doing this procedure make sure water supply is turned on and flowing to the unit. **NEVER** run unit without water supply running through pump.

- Next shut off engine and disconnect the water supply.
- Disconnect the spark plug wire and remove the spark plug.

- Add one teaspoon of oil through the spark plug hole.
- Place rag over spark plug hole and pull the recoil a few times to lubricate the combustion chamber.
- Replace the spark plug, but do not connect the spark plug wire.

Pump Preparation

- Be sure engine switch is in "OFF" position and spark plug wire has been removed from spark plug.
- Pull the trigger on the spray gun to release the pressure in the high pressure hose. Detach high pressure hose and garden hose from the unit.
- Pull the recoil on the engine 4 to 6 times to discharge remaining water in pump.
- Tip the unit on the end with the water inlet fitting pointing upward.
- Pour approximately 1/4 cup of non-toxic R.V. anti-freeze down the fitting where the water hose attaches to the pump.
- Set unit upright and pull starter handle on engine 4 to 6 times to circulate anti-freeze in pump until anti-freeze is discharged from the pump.

TROUBLESHOOTING

SYMPTOM	CAUSE	SOLUTION
Engine won't start	<ol style="list-style-type: none"> 1. Engine throttle is in "OFF" Position. 2. Choke lever has not been placed to choke. 3. Pressure buildup after initial use. 	<ol style="list-style-type: none"> 1. Slide throttle to "Rabbit" position. 2. Slide choke lever to choke position. 3. Depress trigger gun.
Won't Draw Chemical	<ol style="list-style-type: none"> 1. Nozzle not in chemical draw position. 2. Chemical screen is obstructed. 3. Chemical screen not working. 4. Chemical injector orifice obstructed or stuck. 5. Chemical injector closed. 	<ol style="list-style-type: none"> 1. Place nozzle to low pressure. 2. Check chemical screen; clean if obstructed. 3. Make sure chemical screen is submerged in chemical/water. 4. Check and clean. 5. Open chemical injector by turning adjustment knob.
Pump running normally but pressure does not achieve rated values	<ol style="list-style-type: none"> 1. Water supply restricted. 2. Nozzle is in low PSI position. 3. Nozzle incorrect or worn. 4. Pump sucking air. 5. Nozzle blocked. 	<ol style="list-style-type: none"> 1. Check water supply and filter screen for blockage. Check hoses for blockage, kinks, leaks, etc. 2. Twist handle for high pressure. 3. Check and replace. 4. Check that hoses and fittings are air-tight. 5. Clean nozzle.
Fluctuating Pressure	<ol style="list-style-type: none"> 1. Pump sucking air. 2. Garden hose inlet strainer clogged. 3. Worn Seals or Packing. 4. Inadequate water supply. 5. Fouled or dirty inlet or discharge valves. 6. Leaky discharge hose. 	<ol style="list-style-type: none"> 1. Check that hoses and fittings are air tight. Purge air from garden hose. 2. Clean. Check filter frequently. 3. Check and replace. 4. Check hose for kinks. 5. Check flow available to pump. Check for excessive heat, 145° F or above. 6. Clean inlet and discharge valve assemblies. Replace if damaged.
Pressure drops after period of normal use	<ol style="list-style-type: none"> 1. Nozzle clogged, partially obstructed. 2. Nozzle worn. 3. Pump Valves worn, dirty or stuck. 4. Worn pump piston packing. 	<ol style="list-style-type: none"> 1. Use nozzle cleaning kit to clear obstruction. (See Nozzle Maintenance under Service Adjustment.) 2. Clean or replace. 3. Check and replace. 4. Check and replace.
Pump noisy	<ol style="list-style-type: none"> 1. Water too hot. 2. Pump sucking air. 3. Valves dirty or worn. 4. Worn bearings. 	<ol style="list-style-type: none"> 1. Reduce temperature below 63° C or 145° F. 2. Check that hoses and fittings are air tight. 3. Check, clean or replace. 4. Check and replace if necessary.
Presence of water in oil (oil milky).	<ol style="list-style-type: none"> 1. High humidity. 2. Piston packing and oil seal worn. 	<ol style="list-style-type: none"> 1. Change Oil. 2. Check and replace oil seals.
Water dripping from pump	<ol style="list-style-type: none"> 1. Thermal relief functioning normal. 2. Fittings Loose. 3. O-rings of piston guide or retainer worn. 4. Piston packing worn. 	<ol style="list-style-type: none"> 1. Protecting pump, if not using pressure washer for a long period of time, shutoff engine. 2. Tighten. 3. Check and replace. 4. Check and replace.
Oil Dripping	<ol style="list-style-type: none"> 1. Oil seal worn 2. Loose drain plug or worn drain plug o-ring. 	<ol style="list-style-type: none"> 1. Check and replace 2. Tighten drain plug or replace O-ring. Do not over torque.

PUMP PARTS

CRAFTSMAN 3000 PSI HIGH PRESSURE WASHER 919.763010

PUMP NUMBER PK16803

REF. NO.	PART NO.	DESCRIPTION	QTY.	REF. NO.	PART NO.	DESCRIPTION	QTY.
1	AR-960160	O-Ring	6	23	AR-1780070	Piston	3
2	AR-1260162	Plug	6	24	AR-1260100	Piston washer	3
3	AR-1269050	Complete valve	6	25	AR-1260110	Nut	3
4	AR-880830	O-Ring	6	27	AR-740290	O-Ring	2
5	AR-620301	Plug	1	28	AR-880530	Plug	2
6	AR-1780130	Support ring	3	30	AR-1260460	Seal	3
7	AR-1260130	Gasket	3	31	AR-1780100	Rear piston guide	3
8	AR-1780090	Piston guide	3	32	AR-770260	O-Ring	3
9	AR-1780010	Pump body	1	33	AR-1260440	Gasket	3
10	AR-1266740	Cap	1	36	AR-1780380	Head	1
11	AR-1260790	Circlip	1	37	AR-1381550	Washer	8
12	AR-1780550	Snap ring	1	38	AR-680570	Screw	8
13	AR-1780490	Bearing	1	40	AR-1321160	Bearing	1
14	AR-880130	Oil cap	1	41	AR-1321080	Snap ring	1
15	AR-1780050	Piston pin	3	42	AR-480671	Seal	1
16	AR-1780510	O-Ring	1	44	AR-180030	Screw	4
17	AR-1200430	Screw	6	60	AR-1780340	Hollow shaft 0 1	1
18	AR-1789010	Complete cover	1	61	AR-1380550	Gas engine flange	1
19	AR-1780040	Con rod	3	62	AR-1780430	13ushing	1
20	AR-1780060	Guiding piston	3	67	AR-820440	Grub screw	1
21	AR-480480	O-Ring	3	68	AR-1789200	Pump head pre-ass	1
22	AR-1260091	Spacer disc	3	69	16802	Chemical Injector	1
				70	16749	Unloader	
				71	16506	Thermal Relief Valve	1

PARTS KITS							
A=KIT 16739 Valves		B=KIT 16746 Pistons		C=KIT 16748 Oil Seals for D Version			
Pos.	Qty.	Pos.	Qty.	Pos.	Qty.		
3	6	23	3	10	1		
4	6			16	1		
				30	3		
				42	1		
D=KIT 16745 Water Seals		F=KIT 16749 Bearings		L=KIT 16750 Unloader		K=KIT 16802	
Pos.	Qty.	Pos.	Qty.	Pos.	Qty.	Pos.	Qty.
7	3	13	1	70	1	69	1
32	3	40	1				
33	3						

PUMP PARTS

CRAFTSMAN 3000 PSI HIGH PRESSURE WASHER 919.763010

PUMP NUMBER PK16803

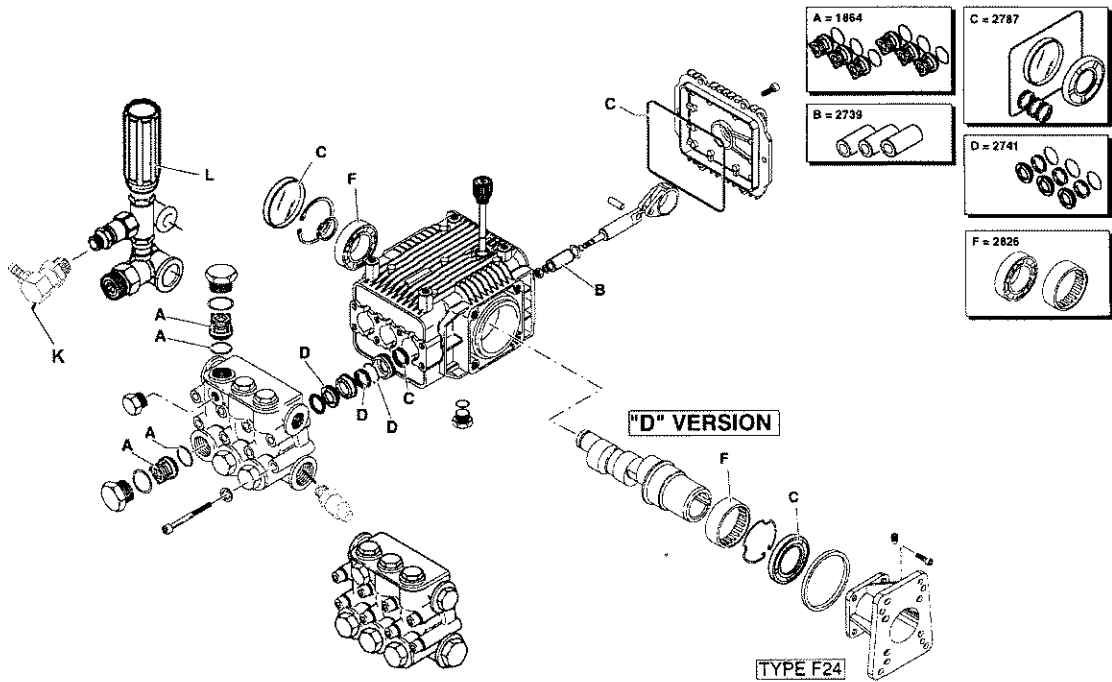
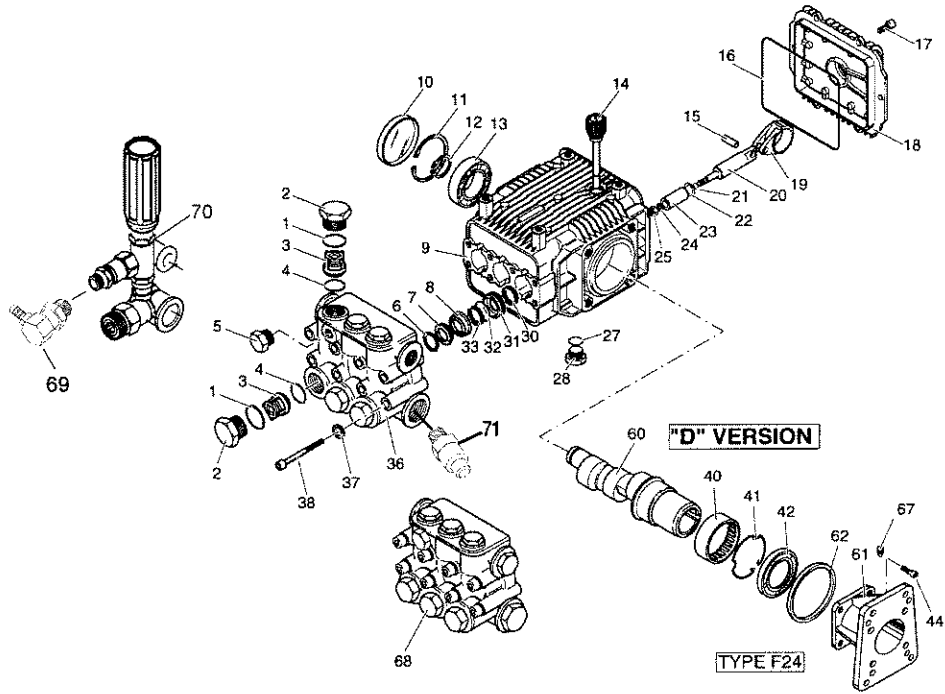

PARTS

CRAFTSMAN 3000 PSI HIGH PRESSURE WASHER 919.763010

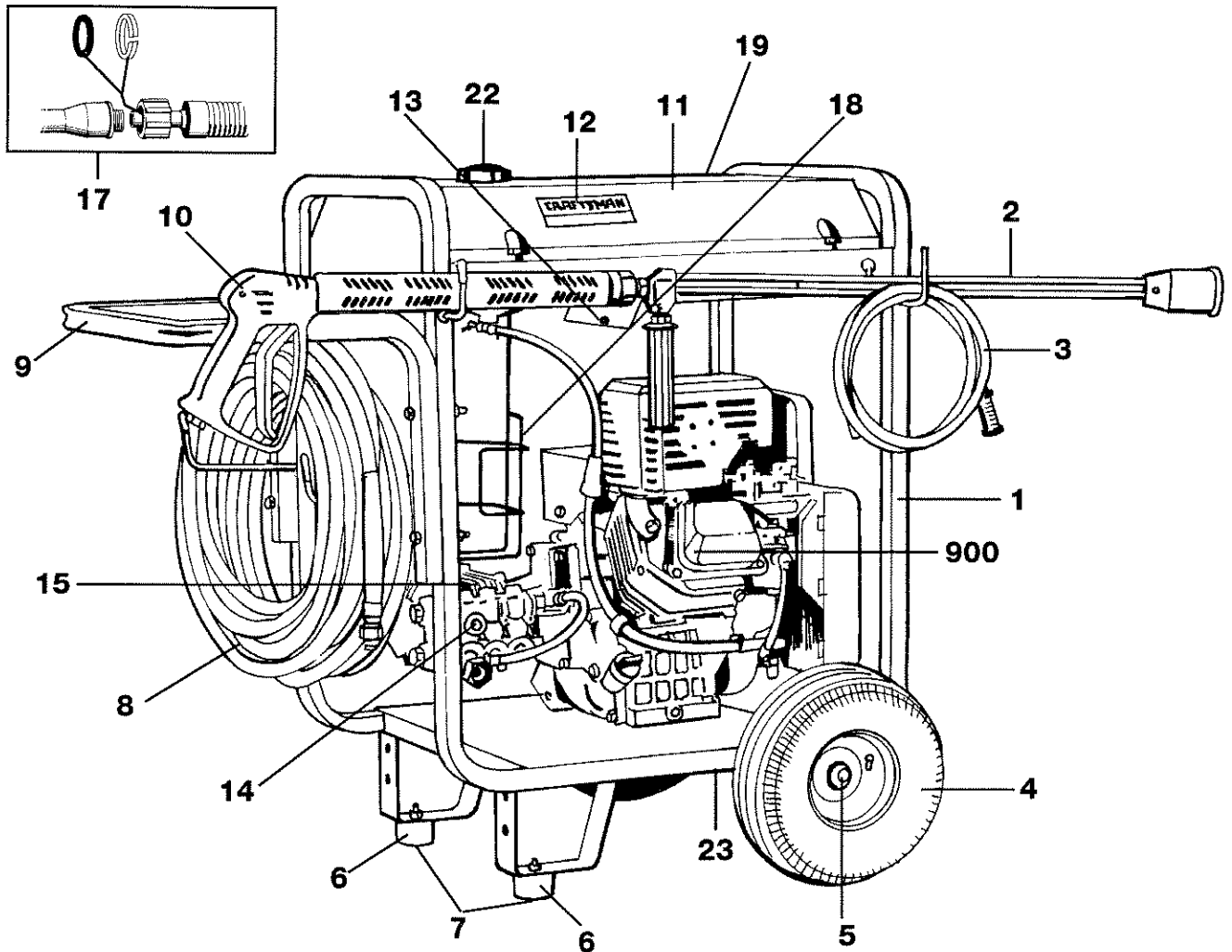

KEY #	PARTNUMBER	DESCRIPTION	KEY #	PARTNUMBER	DESCRIPTION
1	16575	Frame	22	16597	Fuel Cap
2	16824	Dual Lance	23	16611	Axle
3	H100	Chemical Hose	26	F112	Washer, Flat
4	16588	Tire Pnuematic			
5	F464	Nut Pal 5/8"			
6	16371	Rubber Foot			
7	F064	Screw, Hex HDC			
8	15911	Hose			
9	16586	Handle			
10	16496	Gun			
11	16652	Tank			
12	16610	Decal Craftsman			
13	16763	Heat Shield			
14	F039	Hose Quick Connect			
15	PK16803	Pump			
900	----	Engine (Refer to Engine Breakdown Briggs #185432-0035-A1)			
17	16830	O-Ring Kit			
18	16593	Chemical Basket			
19	16728	Decal Operation Instruction			

PARTS NOT ILLUSTRATED

MGP-763010	Owners Manual
F078	Lockwasher, Engine to Frame
F119	Nut Hex 5/16" - Engine to Frame
F066	Screw 5/16" - Engine to Frame
F107	Lockwasher- Pump to Engine
16106	Srew, Hex- Pump to Engine
F074	Flat Washer - Pump to Engine
NCT001	Nozzle Cleaning Tool
16776	Easy Start Valve

ENGINE PARTS

CRAFTSMAN 3000 PSI HIGH PRESSURE WASHER 919.763010

ENGINE NUMBER 185432-0559-E1

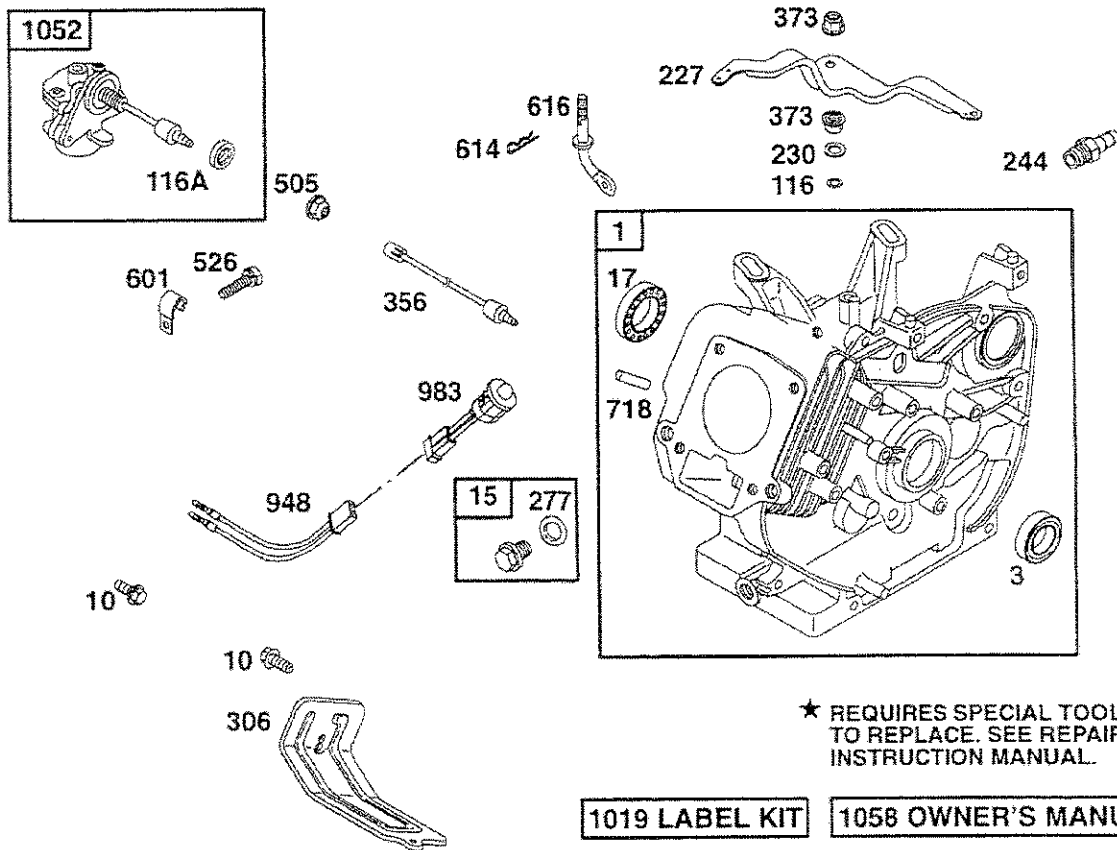

REF. NO.	PART NO.	DESCRIPTION	REF. NO.	PART NO.	DESCRIPTION	REF. NO.	PART NO.	DESCRIPTION
1	715095	Cylinder Assembly	116A	710091	Seal-O-Ring	601	710407	Clamp-Hose
3	710000	Seal-Oil	227	710238	Lever-Governor	614	710056	Pin-Retainer
10	710023	Screw-Hex.	230	710058	Washer-Spacer	616	710050	Crank-Governor
15	715000	Plug-Oil Drain	244	230318	Connector-Hose	718	710005	Pin-Locating
17	710003	Bearing-Ball	277	710004	Washer-Seal	948	710417	Harness-Wiring
116	710055	Seal-O-Ring	306	710242	Shield-Cylinder	1019	715031	Label Kit
			356	710308	Wire-Oil Sensor	1052	715353	Sensor-Oil
			373	710059	Nut-Lock	1053	710408	Module
			493	710085	Bracket-Mounting Used on Type No(s). 0099.			Used on Type No(s). 0099.
			505	710090	Nut-Lock	1058	272983	Owner's Manual
			526	710089	Screw-Hex.			

ENGINE PARTS

CRAFTSMAN 3000 PSI HIGH PRESSURE WASHER 919.763010

ENGINE NUMBER 185432-0559-E1

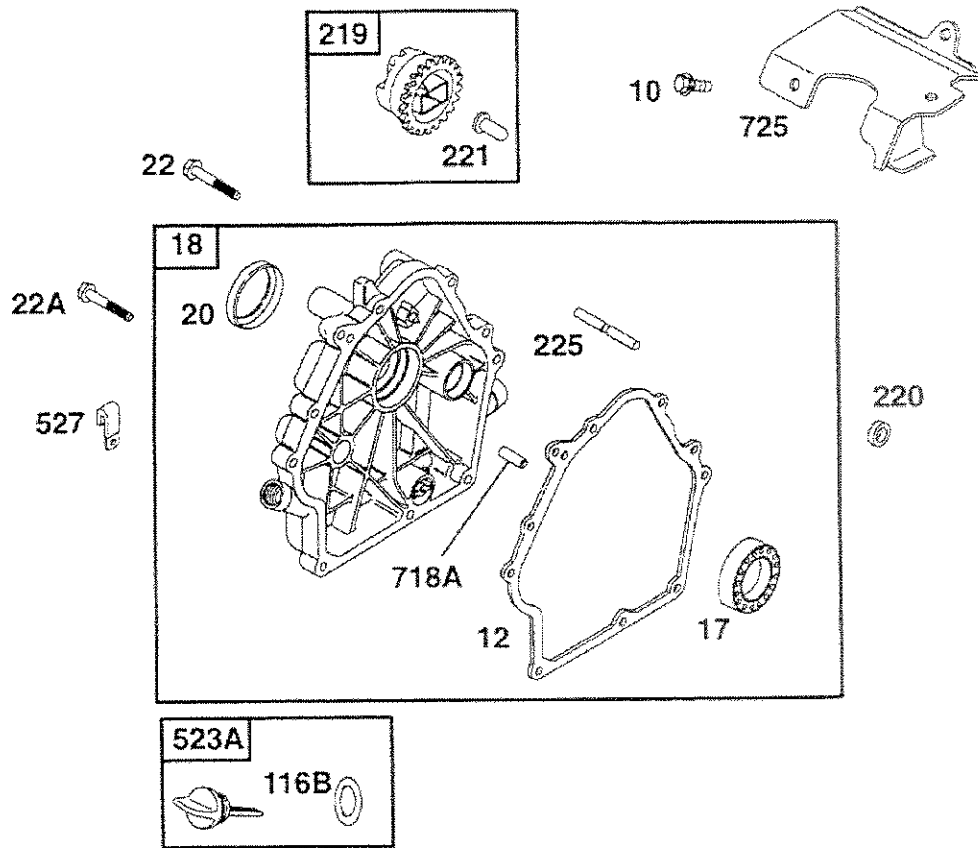

REF. NO.	PART NO.	DESCRIPTION	REF. NO.	PART NO.	DESCRIPTION	REF. NO.	PART NO.	DESCRIPTION
10	710023	Screw-Hex.	20	710215	Seal-Oil	225	710028	Shaft-Governor Gear
12	710216	Gasket-Crankcase	22	710032	Screw-Hex.	524	710394	Seal-Oil
17	710003	Bearing-Ball	22A	710306	Screw-Hex.	525	710391	Tube-Oil Fill
18	715189	Cover-Crankcase	116B	710218	Seal-O-Ring	527	710100	Clamp-Tube
			116C	805386	Seal-O-Ring	718A	710034	Pin-Locating
			219	715006	Gear-Governor	725	710259	Shield-Heat
			220	710035	Washer-Spacer			
			221	710027	Cup-Governor			

ENGINE PARTS

CRAFTSMAN 3000 PSI HIGH PRESSURE WASHER 919.763010

185432-0559-E1

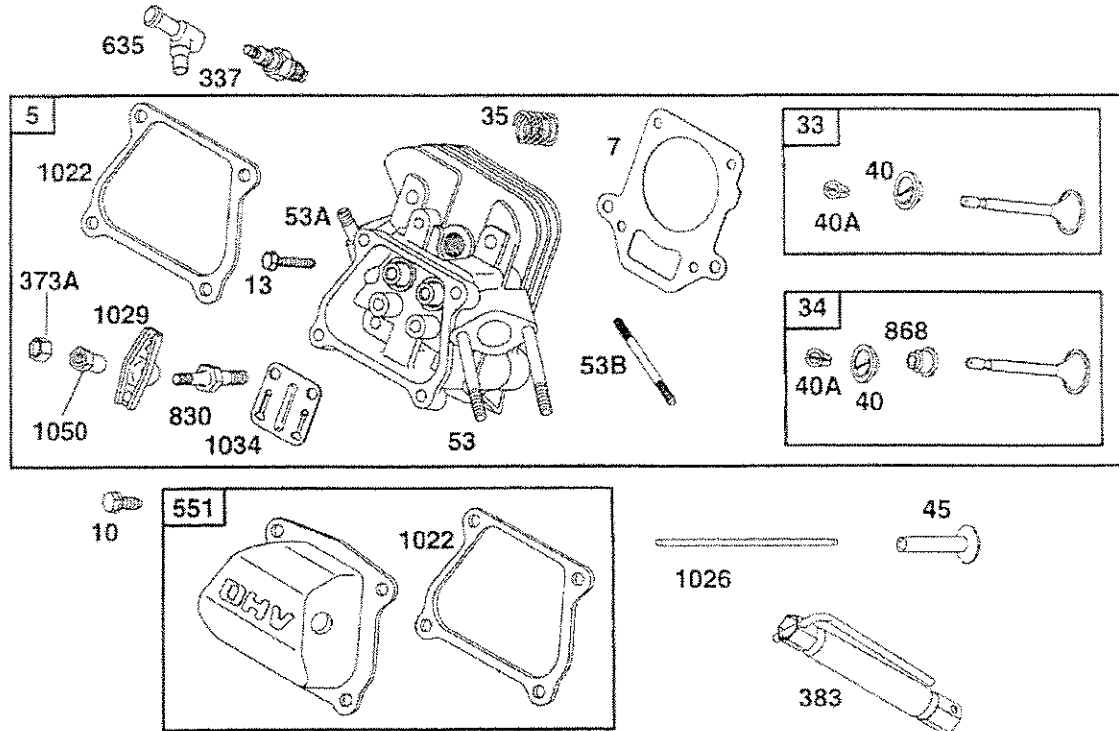

REF. NO.	PART NO.	DESCRIPTION	REF. NO.	PART NO.	DESCRIPTION	REF. NO.	PART NO.	DESCRIPTION
5	715089	Head-Cylinder	53	710233	Stud-Carburetor Mounting	383	19374	Wrench-Spark Plug
7	710205	Gasket-Cylinder Head	53A	710099	Stud	551	715091	Cover-Valve
10	710023	Screw-Hex.	337	491055	Plug-Spark	635	710098	Boot-Spark Plug
13	710204	Screw-Cylinder Head	373A	710007	Nut-Lock	830	710016	Stud-Rocker Arm
33	715085	Valve-Exhaust				868	710019	Seal-Valve
34	715087	Valve-Intake				1022	710206	Gasket-Rocker Cover
35	710209	Spring-Valve				1026	710210	Rod-Push
40	710012	Retainer-Valve				1029	710014	Arm-Rocker
40A	715130	Retainer-Valve				1034	710203	Guide-Push Rod
45	710008	Tappet-Valve				1050	710015	Adjuster-Rocker Arm

ENGINE PARTS

CRAFTSMAN 3000 PSI HIGH PRESSURE WASHER 919.763010

ENGINE NUMBER 185432-0559-E1

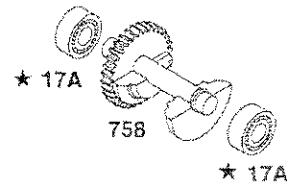
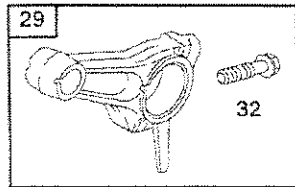
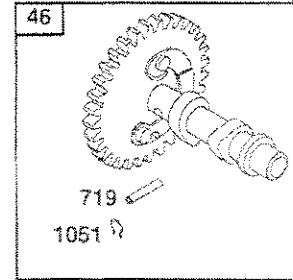
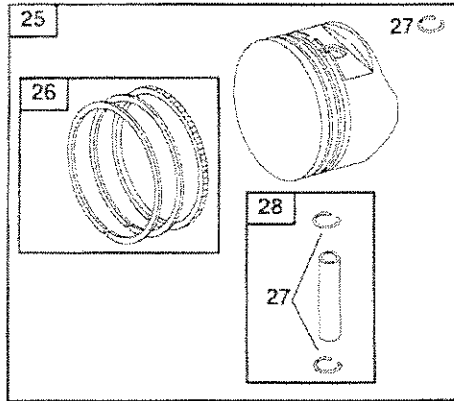

REF. NO.	PART NO.	DESCRIPTION	REF. NO.	PART NO.	DESCRIPTION	REF. NO.	PART NO.	DESCRIPTION
17A	710482	Bearing-Ball Used on Type No(s). 0099.	29	715106	Rod-Connecting (Standard) 715017 Rod- Connecting (.020" Undersize)	719	710219	Pin-Lifter
25	715115	Piston Assy. (Standard) 715116 Piston Assy. (.010" O.S.) 715117 Piston Assy. (.020" O.S.)	32	710221	Screw-Hex.	1051	710039	Ring-Retaining
26	715111	Ring Set (Standard) 715112 Ring Set (.010" O.S.) 715113 Ring Set (.020" O.S.)	46	715249	Gear-Cam			
27	710220	Lock-Piston Pin						
28	715114	Pin-Piston						

ENGINE PARTS

CRAFTSMAN 3000 PSI HIGH PRESSURE WASHER 919.763010

ENGINE NUMBER 185432-0559-E1

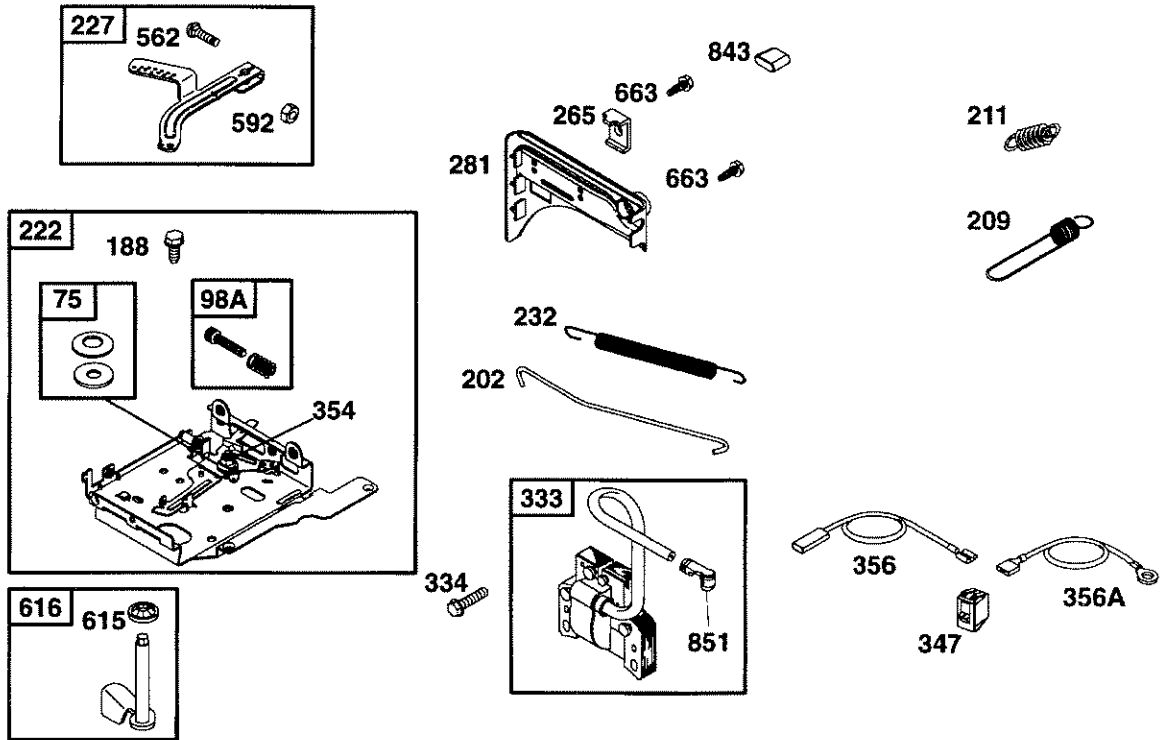

REF. NO.	PART NO.	DESCRIPTION
16	715235	Crankshaft Used on Type No(s). 0035, 0037, 0046, 0059, 0076, 0084, 0099, 0136, 0235

ENGINE PARTS

CRAFTSMAN 3000 PSI HIGH PRESSURE WASHER 919.763010

ENGINE NUMBER 185432-0035-A1

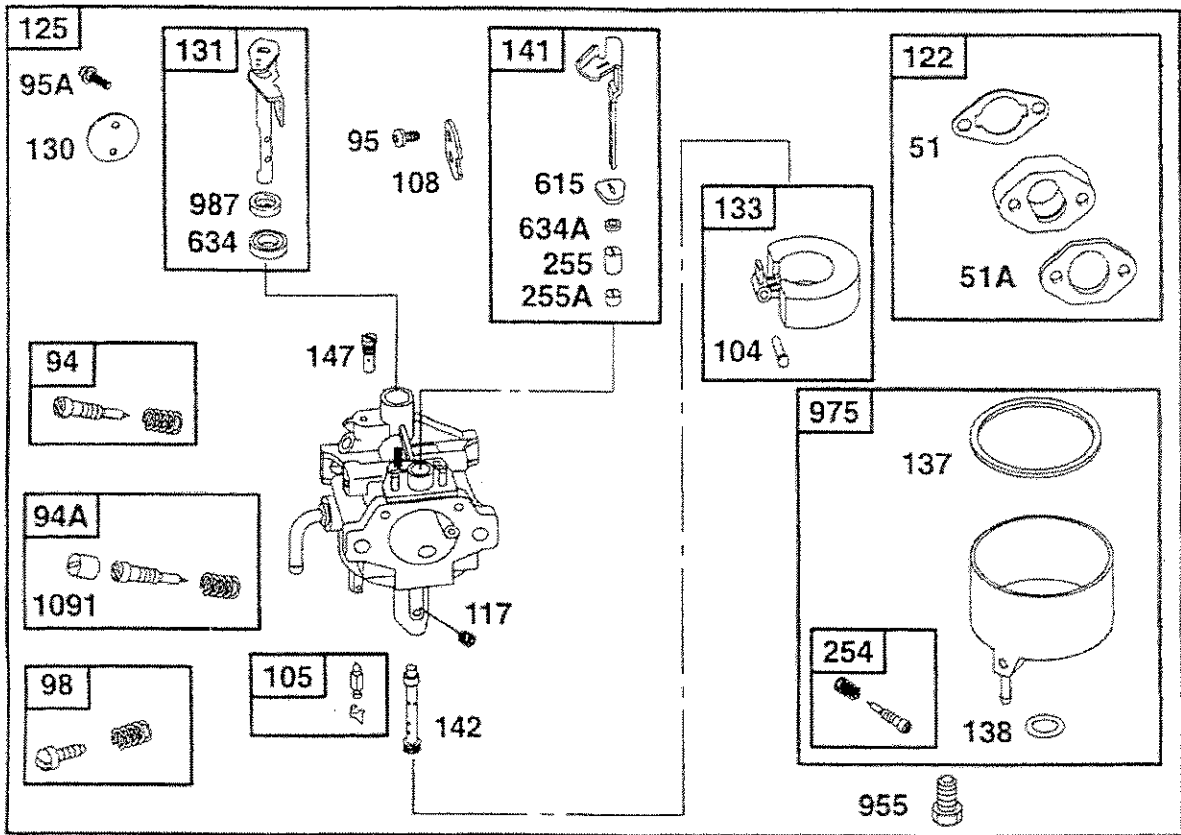

REF. NO.	PART NO.	DESCRIPTION	REF. NO.	PART NO.	DESCRIPTION	REF. NO.	PART NO.	DESCRIPTION
51	710235	Gasket-Intake	125	715121	Carburetor	141	715157	Choke-Shaft Kit
51A	710237	Gasket-Intake	130	710323	Valve-Throttle	142	710317	Nozzle-Carburetor
94	715076	Valve-Idle Adjustment	131	715154	Throttle Shaft Kit	147	710321	Jet-Pilot
94A	715293	Valve-Idle Adjustment Used on Type No(s). 0235.	133	715158	Float-Carburetor			710511 Jet-Pilot (High Altitude)
95	710191	Screw-Choke/Throttle	137		Gasket-Float Bowl (Sold in Kit Only)	254	715049	Drain-Carburetor Bowl
95A	710186	Screw-Round Head	138		Washer (Sold in Kit Only)	255	710177	Bushing-Choke Shaft (Upper)
98	494690	Screw-Idle Speed				255A	710312	Bushing-Choke Shaft (Lower)
104	710310	Pin-Float Hinge				615	710175	Retainer
105	715155	Valve-Needle				634		Washer-Throttle Shaft (Sold in Kit Only)
108	710322	Valve-Choke				634A		Seal-Choke Shaft (Sold in Kit Only)
117	710316	Jet-Main				955	710314	Plug-Carburetor
		710512 Jet-Main (High Altitude)				975	715159	Bowl-Float
122	715120	Spacer-Carburetor				987	710185	Seal-Throttle Shaft
						1091	710485	Cap-Limiter

ENGINE PARTS

CRAFTSMAN 3000 PSI HIGH PRESSURE WASHER 919.763010

ENGINE NUMBER 185432-0035-A1

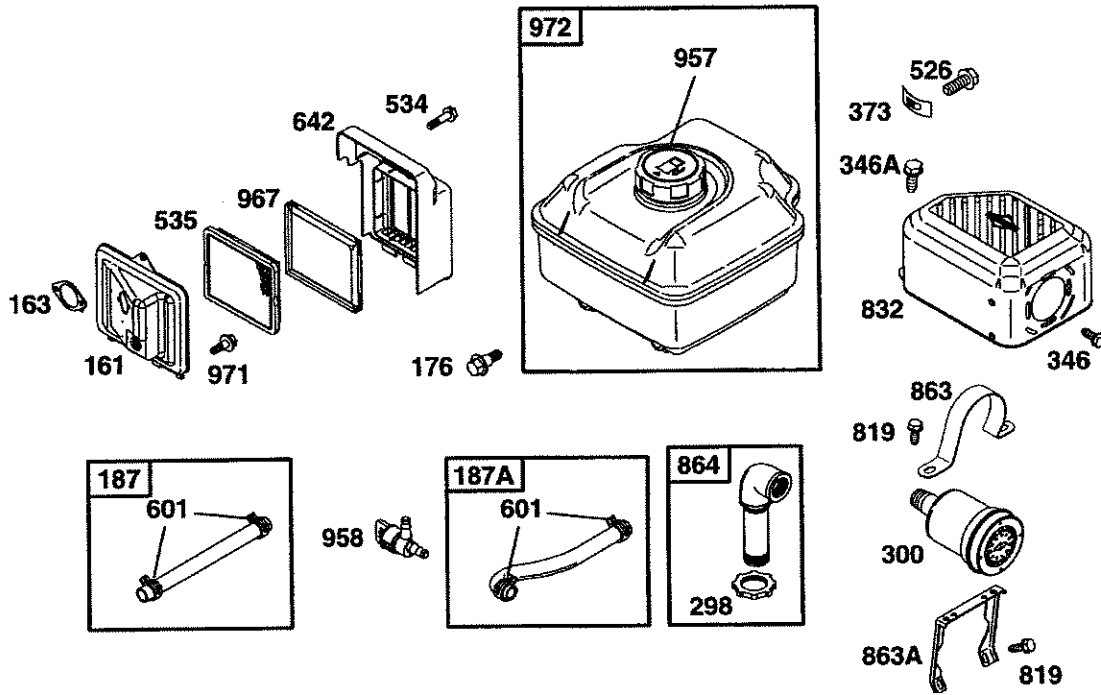

REF. NO.	PART NO.	DESCRIPTION	REF. NO.	PART NO.	DESCRIPTION	REF. NO.	PART NO.	DESCRIPTION
51	710235	Gasket-Intake	209	710258	Spring-Governor	485	280715	Knob-Control
		Note	216	710240	Link-Choke	620	715046	715025 Bracket-Control
		715024 Screw-Governor Speed (Idle & High Speed Adjustments)	232	710241	Spring-Link			Used on Type No(s). 0035, 0037, 0043, 0046, 0047, 0059, 0072, 0076, 0084, 0103, 0106, 0112, 0235.
		Used in Type No(s). 0035, 0037, 0043, 0046, 0047, 0059, 0072, 0076, 0084, 0103, 0106, 0112, 0235.	302	710081	Nut-Hex.	620A	710492	Bracket-Control
						620B	710493	Bracket-Control
						663	710057	Screw-Hex.
						1043	494232	Magnet-Electro

ENGINE PARTS

CRAFTSMAN 3000 PSI HIGH PRESSURE WASHER 919.763010

ENGINE NUMBER 185432-0559-E1

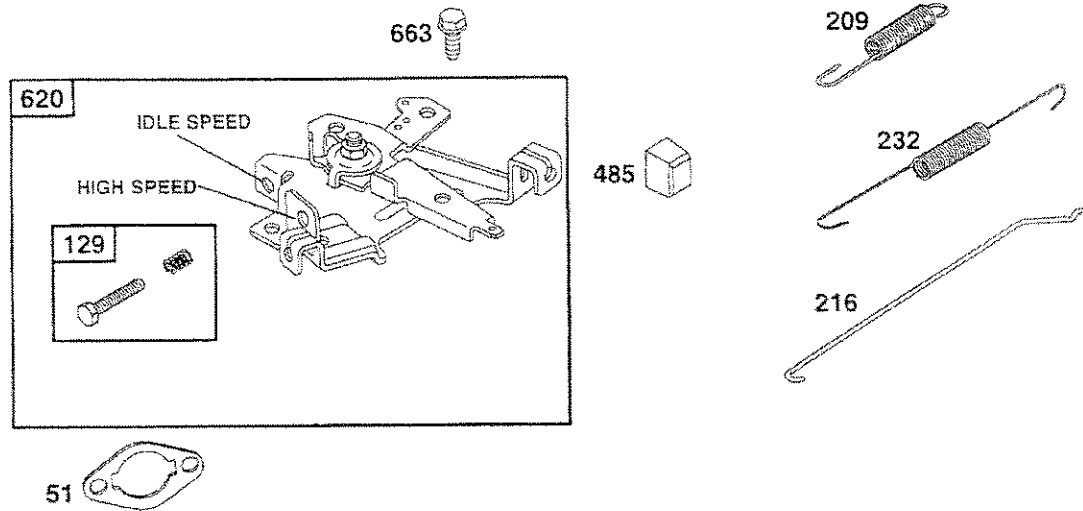

REF. NO.	PART NO.	DESCRIPTION	REF. NO.	PART NO.	DESCRIPTION	REF. NO.	PART NO.	DESCRIPTION
10	710023	Screw-Hex.	116D	280831	Seal-O-Ring	663A	710234	Screw-Hex.
11	710115	Tube-Breather	161	710226	Base-Air Cleaner	967	710226	Filter-Air
51	710235	Gasket-Intake	235	710229	Shield-Fuel Spray	968	710227	Cover-Air Cleaner
51B	272070	Gasket-Intake	354	710068	Nut-Hex.	991	710268	Filter-Air (Pre-Cleaner)
53	710233	Stud-Carburetor Mounting	467	710113	Nut-Air Cleaner			
			643	710228	Retainer-Air Filter			
			646	710232	Brace			

ENGINE PARTS

CRAFTSMAN 3000 PSI HIGH PRESSURE WASHER 919.763010

ENGINE NUMBER 185432-0559-E1

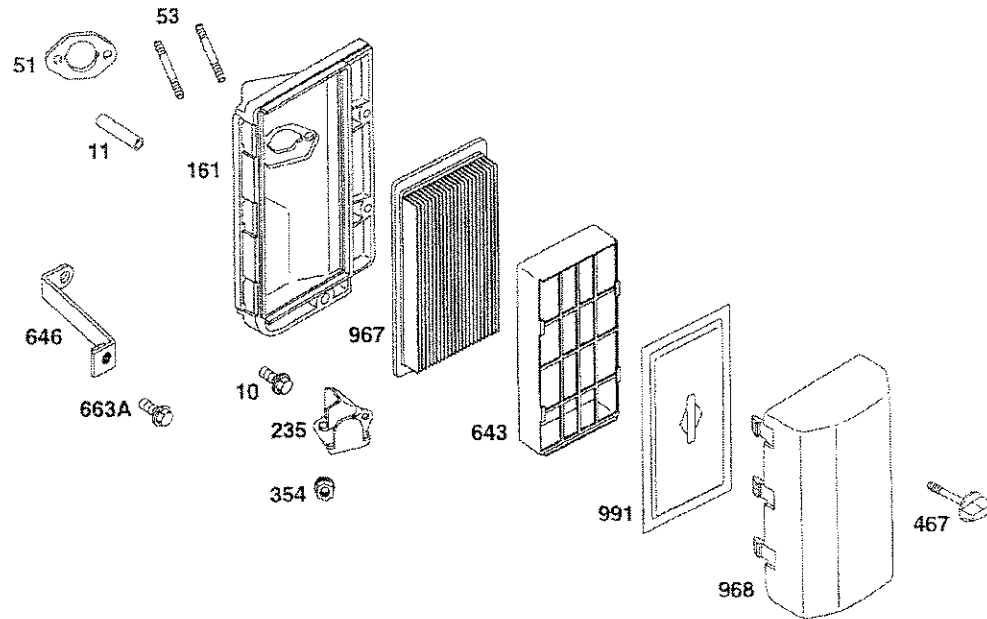

REF. NO.	PART NO.	DESCRIPTION	REF. NO.	PART NO.	DESCRIPTION	REF. NO.	PART NO.	DESCRIPTION
38	710248	Screw-Hex.	210	710065	Strainer-Fuel	529	710246	Grommet
53A	710099	Stud (Muffler Mounting)	300	715127	Muffler-Exhaust	663	710057	Screw-Hex.
180	715129	Tank-Fuel	302	710081	Nut-Hex.	666	710243	Gauge-Fuel
181	710490	Cap-Fuel Tank	346	710307	Screw-Phillips	670	710247	Spacer
182	710244	Bracket-Fuel Tank	354	710068	Nut-Hex.	673	93705	Screw-Hex.
						676	715230	Deflector-Muffler
						737	710074	Screw-Shoulder
						832	710334	Guard-Muffler
						863	715495	Bracket-Muffler
						883	710250	Gasket-Exhaust
						994	715491	Arrester-Spark
						1057	710331	Screen-Outlet

ENGINE PARTS

CRAFTSMAN 3000 PSI HIGH PRESSURE WASHER 919.763010

ENGINE NUMBER 185432-0559-E1

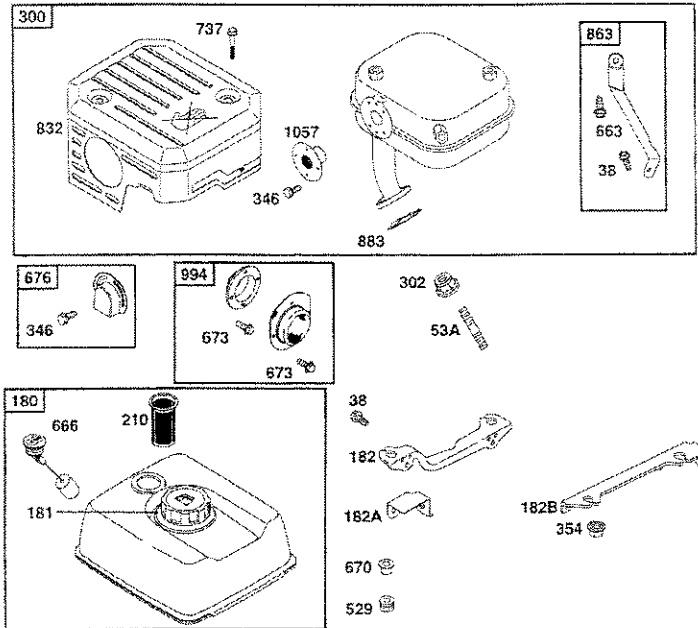

REF. NO.	PART NO.	DESCRIPTION	REF. NO.	PART NO.	DESCRIPTION	REF. NO.	PART NO.	DESCRIPTION
38	710248	Screw-Hex.	187B	296004	Line-Fuel (0.250 in. ID) (Used After Code Date 95073100). (Filter/Shut-Off-To- Fuel Pump) (Carb-To-In Line Filter) (Cut to Required Length)	243	710071	Screen-Filter
116E	710072	Seal-O-Ring	187C	715292	Hose-Vacuum (4MM ID Special Flexible Hose) (Fuel Pump-To-Carb.) (Cut to Required Length)	246	710070	Bowl-Filter
116F	710069	Seal-O-Ring	240	298090	Filter-Fuel Note 493629 Filter-Fuel Used on Type No(s). 0099.	601A	710075	Clamp-Hose
179	715172	Line-Fuel (Used Before Code Date 95080100). Used on Type No(s). 0037, 0041, 0042, 0071, 0078, 0075, 0077, 0082.	240A	715027	Filter-Fuel Note 715224 Filter-Fuel Used on Type No(s). 0103.	601B	710067	Clamp-Hose
187	715125	Line-Fuel (8mm ID) (Fuel Tank-To Filter/ Shut-Off) (Cut to Required Length)				601C	95053	Clamp-Hose
187A	715126	Line-Fuel (4mm ID) (Filter/Shut-Off-To- Carburetor) (Cut to Required Length)				663A	710234	Screw-Hex.
						663B	710160	Screw-Hex.
						670A	710159	Spacer-Fuel Tank

ENGINE PARTS

CRAFTSMAN 3000 PSI HIGH PRESSURE WASHER 919.763010

ENGINE NUMBER 185432-0559-E1

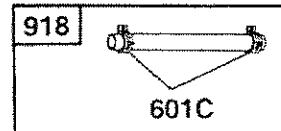
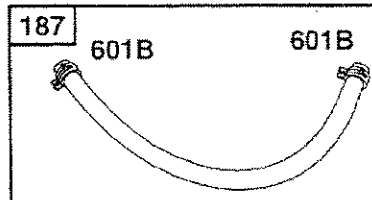
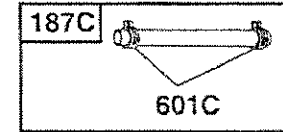
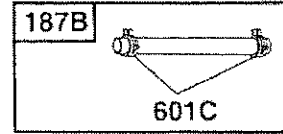
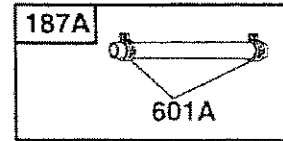
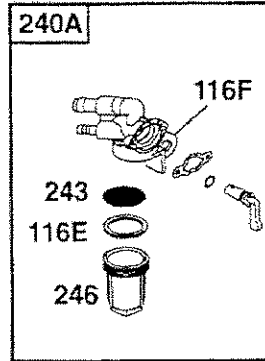
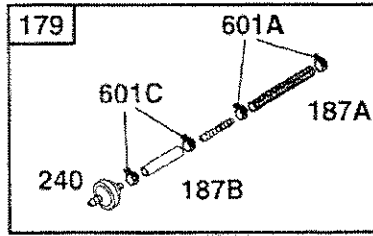

REF. NO.	PART NO.	DESCRIPTION	REF. NO.	PART NO.	DESCRIPTION	REF. NO.	PART NO.	DESCRIPTION
281	715321	Panel-Control (Used After Code Date 96010100). Used on Type No(s). 0035-01, 0035-02, 0046, 0047-01, 0047-09, 0051, 0070, 0071, 0072-01, 0078-02, 0090, 0103, 0107.	305	710095	Screw-Hex.			Replaced with Panel-Control:
			347	493521	Switch-Rocker (Without Light)			715321 for Non-Elec-
			347A	495098	Switch-Rocker (With Light)			tric Start Engine
			356E	715202	Wire-Stop			715322 for Electric
			447	710253	Screw-Hex.	892	715199	Start Engine
			493	710363	Bracket-Mounting			Key Switch
			493A	710717	Bracket-Mounting			Note
			663	710057	Screw-Hex.			710716 Key Switch
			663A	710234	Screw-Hex.			Used on Type No(s).
			737	710074	Screw-Hex.	925	710252	0059, 0084.
			890A	710094	Bracket-Support (Used Before Code Date 96010200).			Cover-Linkage (Used Before Code Date 96010200).
								Replaced with Panel-Control:
								715321 for Non-Elec-
								tric Start Engine
								715322 for Electric
								Start Engine
						990	715203	Key Set
						1054	710349	Tie-Cable

ENGINE PARTS

CRAFTSMAN 3000 PSI HIGH PRESSURE WASHER 919.763010

ENGINE NUMBER 185432-0559-E1

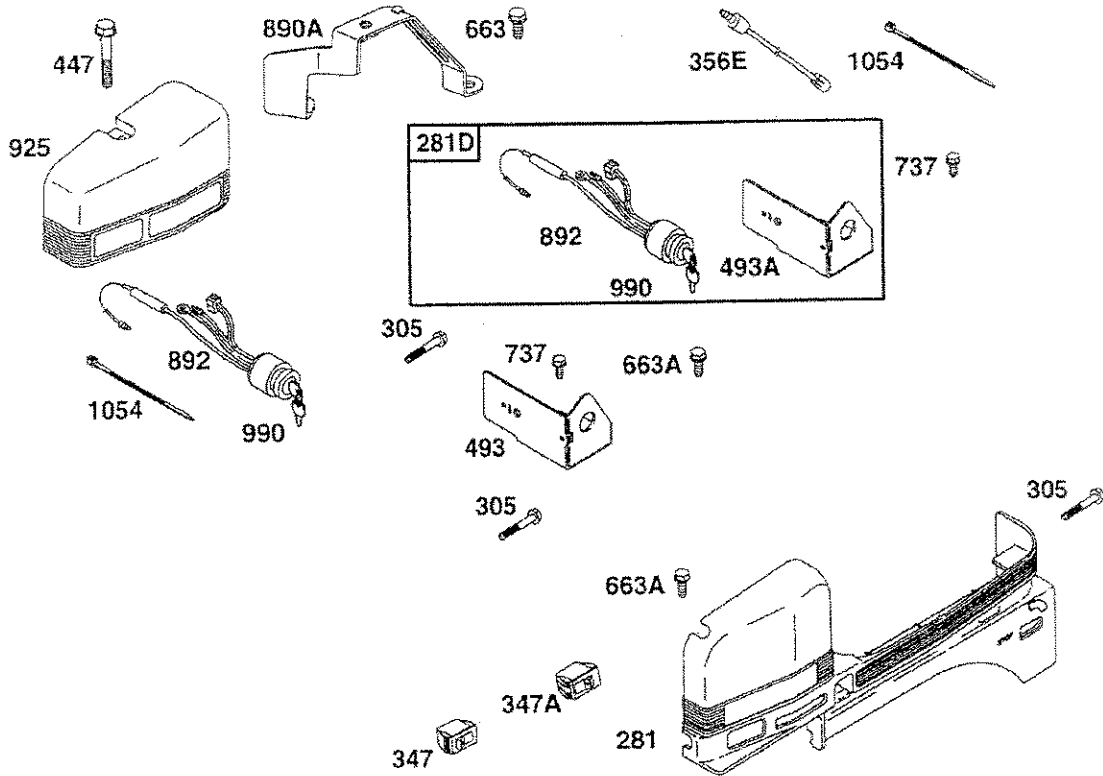

REF. NO.	PART NO.	DESCRIPTION	REF. NO.	PART NO.	DESCRIPTION	REF. NO.	PART NO.	DESCRIPTION
10	710223	Screw-Hex.	333	715118	Armature-Magneto	475	715200	Rectifier
23	710224	Flywheel	334	710047	Screw-Hex.	521	710045	Shielding-Cable
73	224757	Screen-Rotating	356A	710087	Wire-Stop (Black)	526	710089	Screw-Hex.
304	710364	Housing-Blower	356B	710120	Wire-Stop (Red)	663A	710234	Screw-Hex.
332	710048	Nut-Hex.	356C	710121	Wire-Stop (White)	729	710046	Clip-Lead Wire
332A	710345	Nut-Hex.	356D	710324	Wire-Ground	813	710083	Clamp
					Note	1036	499351	Label Kit-Emission
					710097 Wire-Ground			Used on Type No(s).
					Used on Type No(s).			0235.
					0099.	1053	710305	Module
			455	710366	Cup-Flywheel			
					(Used After Code Date			
					93123100).			
			455A	710257	Cup-Flywheel			
					(Used Before Code			
					Date 94010100).			
					Note			
					710230 Cup-Flywheel			
					Used on Type No(s).			
					0072.			

ENGINE PARTS

CRAFTSMAN 3000 PSI HIGH PRESSURE WASHER 919.763010

ENGINE NUMBER 185432-0559-E1

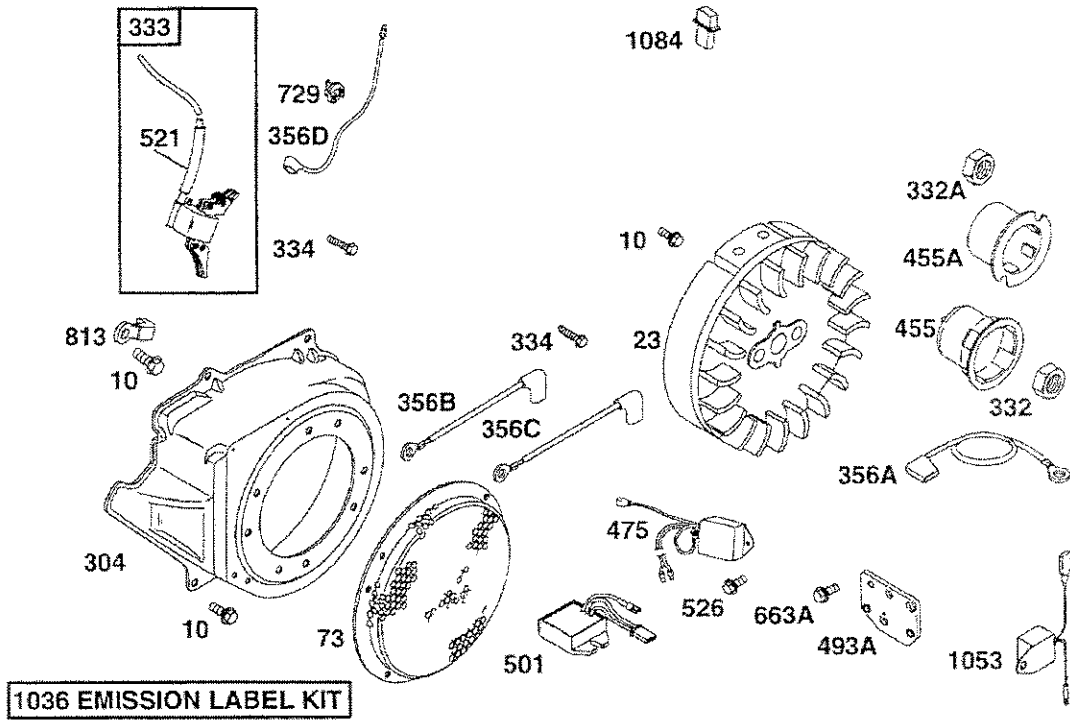

REF. NO.	PART NO.	DESCRIPTION	REF. NO.	PART NO.	DESCRIPTION	REF. NO.	PART NO.	DESCRIPTION
55	808186	Housing-Rewind Starter	59	805957	Insert-Grip	608	808087	Starter-Rewind Note
56	805949	Pulley-Starter	60	808167	Grip-Starter Rope			715204 Starter-Rewind
57	805951	Spring-Rewind Starter	456	805954	Plate-Pawl Friction			(Used Before Code Date 94010100).
58	66574	Rope-Starter (Cut to Required Length)	459	808166	Pawl-Ratchet	615	805952	Ring-Rewind Starter
			461	805955	Screw-Shoulder	737	710074	Screw-Hex.
			515	805953	Spring-Pawl			

ENGINE PARTS

CRAFTSMAN 3000 PSI HIGH PRESSURE WASHER 919.763010

ENGINE NUMBER 185432-0559-E1

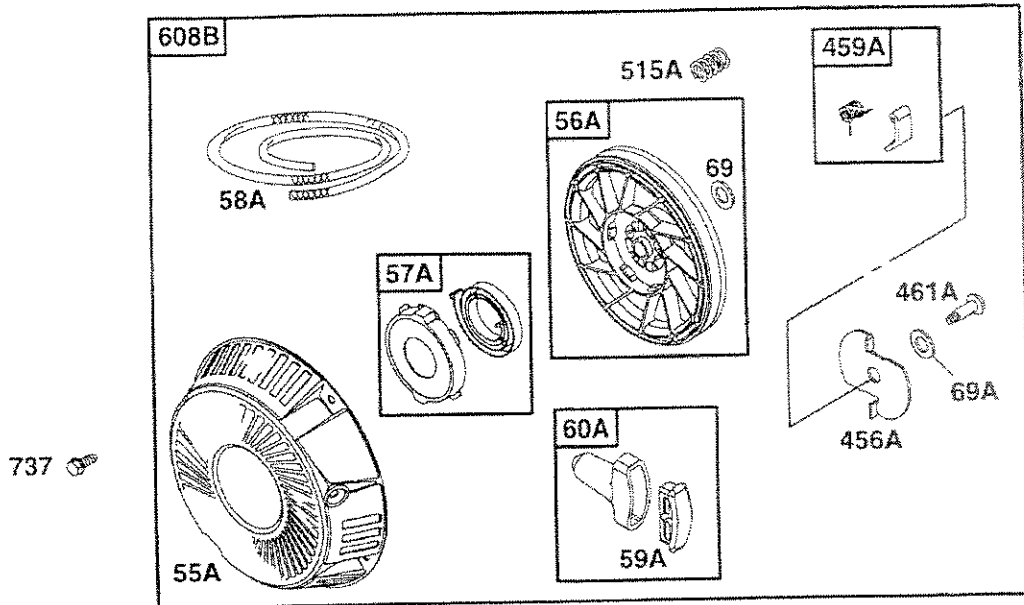

REF. NO.	PART NO.	DESCRIPTION	REF. NO.	PART NO.	DESCRIPTION	REF. NO.	PART NO.	DESCRIPTION
55A	492193	Housing-Rewind Starter	59A	490653	Insert-Grip	515A	262564	Spring-Friction
56A	494956	Pulley-Starter	60A	490652	Grip-Starter Rope	608B	715204	Starter-Rewind
57A	492194	Spring-Rewind Starter	69	94464	Washer	737	710074	Screw-Hex.
58A	66894	Rope-Starter (Cut to Required Length).	69A	94462	Washer			
			456A	224228	Plate-Pawl Friction			
			459A	492431	Pawl Ratchet			
			461A	94463	Screw-Shoulder			

ENGINE PARTS

CRAFTSMAN 3000 PSI HIGH PRESSURE WASHER 919.763010

ENGINE NUMBER 185432-0559-E1

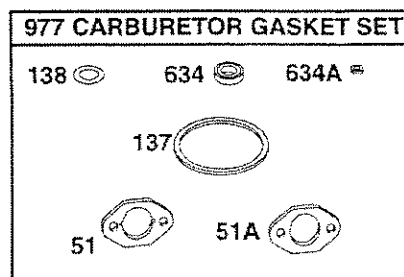
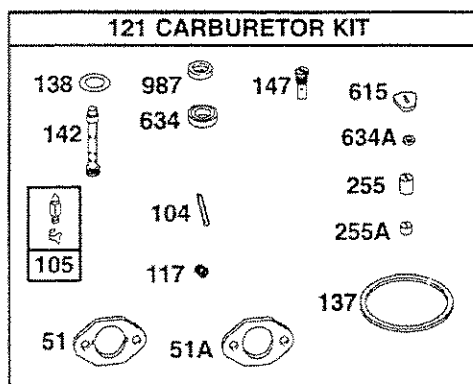
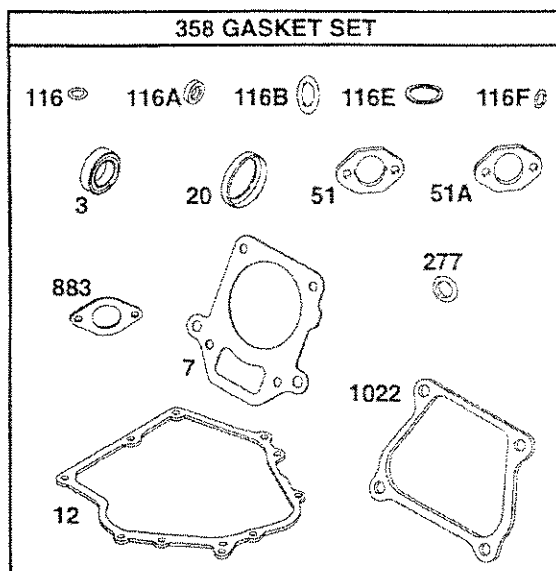
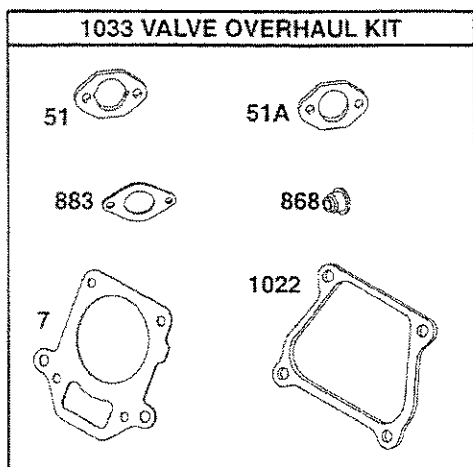

REF. NO.	PART NO.	DESCRIPTION	REF. NO.	PART NO.	DESCRIPTION	REF. NO.	PART NO.	DESCRIPTION
3	710000	Seal-Oil	117	710316	Jet-Main	358	715124	Gasket Set
7	710205	Gasket-Cylinder Head	121	715156	Carburetor Kit	615	710175	Retainer
12	710216	Gasket-Crankcase	137		Gasket-Float Bowl (Sold in Kit Only)	634		Washer-Throttle Shaft (Sold in Kit Only)
20	710215	Seal-Oil	138		Washer (Sold in Kit Only)	634A		Seal-Choke Shaft (Sold in Kit Only)
51	710235	Gasket-Intake	142	710317	Nozzle-Carburetor	868	710019	Seal-Valve
51A	710237	Gasket-Intake	147	710321	Jet-Pilot	883	710250	Gasket-Exhaust
104	710310	Pin-Float Hinge	255	710177	Bushing-Choke Shaft (Upper)	977	715160	Gasket Set-Carburetor
105	715155	Valve-Needle	255A	710312	Bushing-Choke Shaft (Lower)	987	710185	Seal-Throttle Shaft
116	710055	Seal-O-Ring	277	710004	Washer-Seal	1022	710206	Gasket-Rocker Cover
116A	710091	Seal-O-Ring				1033	715123	Kit-Valve Overhaul
116B	710218	Seal-O-Ring						
116E	710072	Seal-O-Ring						
116F	710069	Seal-O-Ring						

**Briggs & Stratton Corporation (B&S), the California Air Resources Board (CARB)
and the United States Environmental Protection Agency (U.S. EPA)**

Emission Control System Warranty Statement (Owner's Defect Warranty Rights and Obligations)

In the interest of the environment, B&S engines that meet strict emission requirements are labeled, "This engine conforms to 1995 - 1998 California emission regulations for ULGE engines and U.S. EPA Phase I regulations for small non-road engines."

EMISSION CONTROL WARRANTY COVERAGE IS APPLICABLE

California and United States Emission Control Defects Warranty Statement

CARB, U.S. EPA and B&S are pleased to explain the Emission Control System Warranty on your 1996 and later utility or lawn and garden equipment (ULGE) engine. In California, new ULGE engines produced on or after August 1, 1995 must be designed, built and equipped to meet the State's stringent anti-smog standards. Elsewhere in the United States, new non-road, spark-ignition engines certified for model year 1997 and later, must meet similar standards set forth by the U.S. EPA. B&S must warrant the emission control system on your engine for the periods of time listed below, provided

Briggs & Stratton Emission Control Defects Warranty Coverage

ULGE engines are warranted relative to emission control parts defects for a period of two years, subject to provisions set forth

Owner's Warranty Responsibilities

As the ULGE engine owner, you are responsible for the performance of the required maintenance listed in your Operator/Owner Manual. B&S recommends that you retain all your receipts covering maintenance on your ULGE engine, but B&S cannot deny warranty solely for the lack of receipts or for your failure to ensure the performance of all scheduled maintenance.

As the ULGE engine owner, you should however be aware that B&S may deny you warranty coverage if your ULGE engine or a part has failed due to abuse, neglect, improper maintenance or unapproved modifications.

Briggs & Stratton Emission Control Defects Warranty Provisions

The following are specific provisions relative to your Emission Control Defects Warranty Coverage. It is in addition to the B&S engine warranty for non-regulated engines found in the Operator/Owner Manual.

1. Warranted Parts

Coverage under this warranty extends only to the parts listed below (the emission control systems parts) to the extent these parts were present on the engine purchased.

a. Fuel Metering System

- Cold start enrichment system (soft choke)
- Carburetor and internal parts
- Fuel Pump

b. Air Induction System

- Air cleaner
- Intake manifold

c. Ignition System

- Spark plug(s)
- Magneto ignition system

d. Catalyst System

- Catalytic converter
- Exhaust manifold
- Air injection system or pulse valve

e. Miscellaneous Items Used in Above Systems

- Vacuum, temperature, position, time sensitive valves and switches
- Connectors and assemblies

2. Length of Coverage

B&S warrants to the initial owner and each subsequent purchaser that the Warranted Parts shall be free from defects in materials and workmanship which caused the failure of the Warranted Parts for a period of two years from the date the engine is delivered to a retail purchaser.

TO CERTIFIED ENGINES PURCHASED IN CALIFORNIA IN 1995 AND THEREAFTER, WHICH ARE USED IN CALIFORNIA, AND TO CERTIFIED MODEL YEAR 1997 AND LATER ENGINES WHICH ARE PURCHASED AND USED ELSEWHERE IN THE UNITED STATES.

there has been no abuse, neglect or improper maintenance of your ULGE engine.

Your emission control system includes parts such as the carburetor, air cleaner, ignition system, muffler and catalytic converter. Also included may be connectors and other emission related assemblies.

Where a warrantable condition exists, B&S will repair your ULGE engine at no cost to you including diagnosis, parts and labor.

below. If any covered part on your engine is defective, the part will be repaired or replaced by B&S.

You are responsible for presenting your ULGE engine to an Authorized B&S Service Dealer as soon as a problem exists. The undisputed warranty repairs should be completed in a reasonable amount of time, not to exceed 30 days.

If you have any questions regarding your warranty rights and responsibilities, you should contact a B&S Service Representative at 1-414-259-5262.

The emission warranty is a defects warranty. Defects are judged on normal engine performance. The warranty is not related to an in-use emission test.

3. No Charge

Repair or replacement of any Warranted Part will be performed at no charge to the owner, including diagnostic labor which leads to the determination that a Warranted Part is defective, if the diagnostic work is performed at an Authorized B&S Service Dealer. For emissions warranty service contact your nearest Authorized B&S Service Dealer as listed in the "Yellow Pages" under "Engines, Gasoline," "Gasoline Engines," "Lawn Mowers," or similar category.

4. Claims and Coverage Exclusions

Warranty claims shall be filed in accordance with the provisions of the B&S Engine Warranty Policy. Warranty coverage shall be excluded for failures of Warranted Parts which are not original B&S parts or because of abuse, neglect or improper maintenance as set forth in the B&S Engine Warranty Policy. B&S is not liable to cover failures of Warranted Parts caused by the use of add-on, non-original, or modified parts.

5. Maintenance

Any Warranted Part which is not scheduled for replacement as required maintenance or which is scheduled only for regular inspection to the effect of "repair or replace as necessary" shall be warranted as to defects for the warranty period. Any Warranted Part which is scheduled for replacement as required maintenance shall be warranted as to defects only for the period of time up to the first scheduled replacement for that part. Any replacement part that is equivalent in performance and durability may be used in the performance of any maintenance or repairs. The owner is responsible for the performance of all required maintenance, as defined in the B&S Operator/Owner Manual.

6. Consequential Coverage

Coverage hereunder shall extend to the failure of any engine components caused by the failure of any Warranted Part still under warranty.

Briggs & Stratton welcomes warranty repair and apologizes to you for being inconvenienced. Any Authorized Service Dealer may perform warranty repairs. Most warranty repairs are handled routinely, but sometimes requests for warranty service may not be appropriate. For example, warranty would not apply if engine damage occurred because of misuse, lack of routine maintenance, shipping, handling, warehousing or improper installation. Similarly, warranty is void if the serial number of the engine has been removed or the engine has been altered or modified.

If a customer differs with the decision of the Service-Dealer, an investigation will be made to determine whether the warranty applies. Ask the Service Dealer to submit all supporting facts to his Distributor or the Factory for review. If the Distributor or the Factory decides that the claim is justified, the customer will be fully reimbursed for those items that are defective. To avoid misunderstanding which might occur between the customer and the Dealer, listed below are some of the causes of engine failure that the warranty does not cover.

Improper maintenance:

The life of an engine depends upon the conditions under which it operates, and the care it receives. Some applications, such as tillers, pumps and rotary mowers, are very often used in dusty or dirty conditions, which can cause what appears to be premature wear. Such wear, when caused by dirt, dust, spark plug cleaning grit, or other abrasive material that has entered the engine because of improper maintenance, is not covered by warranty.

This warranty covers engine related defective material and/or workmanship only, and not replacement or refund of the equipment to which the engine may be mounted. Nor does the warranty extend to repairs required because of:

1. PROBLEMS CAUSED BY PARTS THAT ARE NOT ORIGINAL BRIGGS & STRATTON PARTS.
2. Equipment controls or installations that prevent starting, cause unsatisfactory engine performance, or shorten engine life. (Contact equipment manufacturer.)
3. Leaking carburetors, clogged fuel pipes, sticking valves, or other damage, caused by using contaminated or stale fuel. (Use clean, fresh, lead-free gasoline and Briggs & Stratton gasoline stabilizer, Part No. 5041.)

4. Parts which are scored or broken because an engine was operated with insufficient or contaminated lubricating oil, or an incorrect grade of lubricating oil (check oil level daily or after every 8 hours of operation. Refill when necessary and change at recommended intervals.) Read "Owner's Manual."
5. Repair or adjustment of associated parts or assemblies such as clutches, transmissions, remote controls, etc., which are not manufactured by Briggs & Stratton.
6. Damage or wear to parts caused by dirt, which entered the engine because of improper air cleaner maintenance, re-assembly, or use of a non-original air cleaner element or cartridge. (At recommended intervals, clean and re-oil the Oil-Foam® element or the foam pre-cleaner, and replace the cartridge.) Read "Owner's Manual."
7. Parts damaged by overspeeding, or overheating caused by grass, debris, or dirt, which plugs or clogs the cooling fins, or flywheel area, or damage caused by operating the engine in a confined area without sufficient ventilation. (Clean fins on the cylinder, cylinder head and flywheel at recommended intervals.) Read "Owner's Manual."
8. Engine or equipment parts broken by excessive vibration caused by a loose engine mounting, loose cutter blades, unbalanced blades or loose or unbalanced impellers, improper attachment of equipment to engine crankshaft, overspeeding or other abuse in operation.
9. A bent or broken crankshaft, caused by striking a solid object with the cutter blade of a rotary lawn mower, or excessive v-belt tightness.
10. Routine tune-up or adjustment of the engine.
11. Engine or engine component failure, i.e., combustion chamber, valves, valve seats, valve guides, or burned starter motor windings, caused by the use of alternate fuels such as, liquified petroleum, natural gas, altered gasolines, etc.

For the repair or replacement parts you need

Call 7 am - 7 pm, 7 days a week

1-800-366-PART

(1-800-366-7278)

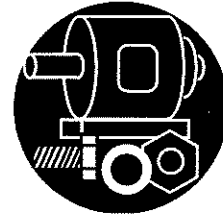

For in-home major brand repair service

Call 24 hours a day, 7 days a week

1-800-4-REPAIR

(1-800-473-7247)



**For the location of a
Sears Parts and Repair Center in your area**

Call 24 hours a day, 7 days a week

1-800-488-1222



**For information on purchasing a Sears
Maintenance Agreement or to inquire
about an existing Agreement**

call 9 am - 5 pm, Monday-Saturday

1-800-827-6655



SEARS
REPAIR SERVICES
America's Repair Specialists

MANUAL DEL OPERADOR

CRAFTSMAN[®]

Lavadora de Alta Presión

9 Caballos de Fuerza

3000 PSI 3 GPM

Modelo No.
919.763010

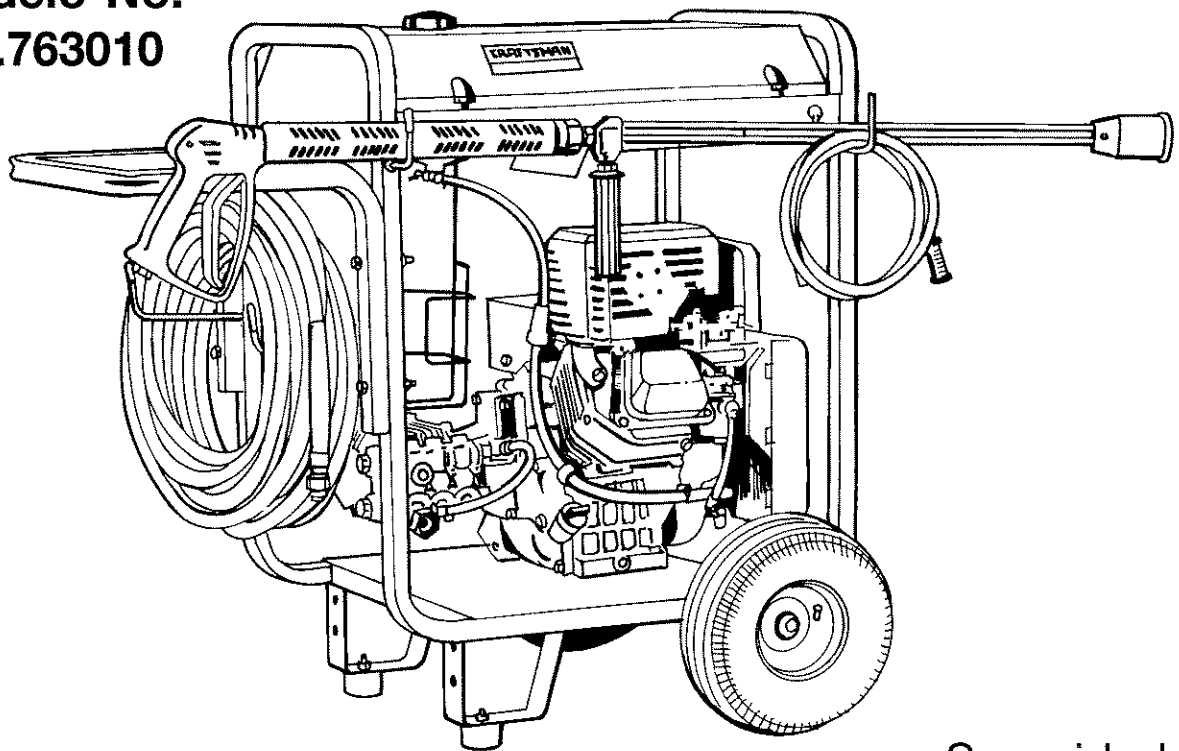

ADVERTENCIA: Leer este manual y observar todas las Precauciones de Seguridad e Instrucciones de Operación antes de usar este equipo.

TELÉFONO DE AYUDA
PARA CLIENTES DE
LAVADORAS A PRESIÓN
1-800-245-5873

- Seguridad
- Ensamblaje
- Operación
- Mantenimiento
- Lista de Partes
- Español

Sears, Roebuck and Co., Hoffman Estates, IL 60179 U.S.A.

**PARA LISTE DE PARTES
VEA LA PAGINA 18
VERSION EN INGLES**